

Sefam S.BOX

BY
STARCK®



OPTIONAL HEATED HUMIDIFIER

Service Manual

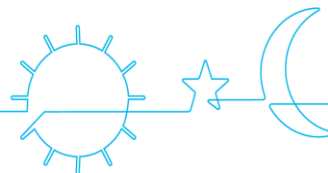

en

Manufacturer:	Manufacturing and technical service location:
SEFAM 144 AV CHARLES DE GAULLE 92200 NEUILLY SUR SEINE FRANCE	SEFAM 10 ALLEE PELLETIER DOISY 54600 VILLERS-LES-NANCY FRANCE TEL: +33 (0) 3 83 44 85 00 www.Sefam-medical.com Technical assistance: TEL.: +33 (0) 3 83 44 85 17 E:mail: technicalservice@sefam-medical.com

CONTENTS

Features of the device	7
Heated humidification	7
Intelligent Start.....	7
Mask Fit & Go	7
Mask unplugged	7
Comfort Control Plus	7
Information and settings	9
Using the SD card	23
Cleaning and maintenance	24
Daily.....	24
Weekly	24
Monthly.....	25
Disinfecting the materials	26
Disinfecting the surface of the device	26
Disinfecting the humidifier chamber (if humidifier is installed)	26
Things never to use.....	27
Troubleshooting tips	28
Device Messages.....	28
Error Messages.....	29
Technical characteristics	30
Performance of the device	30
Humidifier performance	30
Conditions of use.....	31
Transport and storing conditions	31
Electrical characteristics	31
Physical characteristics	32
Definition of symbols	32
CE marking	33
Regulatory Requirements	33
End of life disposal of the device	33
Electromagnetic Compatibility.....	34
Special characteristics according to the standard NF EN ISO 17510-1:2009	35
Functional diagram of the internal pneumatic circuit.....	37
Maintenance	38
Disassembly instructions.....	39
Assembly instructions	45
Pressure Verification.....	54
Spare parts.....	55

Before you start

This user guide is intended for Physicians & Home Care Providers. Under no condition should it be given to patients.

Safety guidelines

WARNING:

It means that there is a possibility of danger risk of injuries or accident to patient.

- Please take note of the safety measures indicated in the SEFAM S.Box[®] Patient Manual.
- See Patient Manual for instructions on how to install, maintain and store the device.
- It is imperative that each patient is provided with the Patient Manual as well as the accessory use instructions.
- Use this device only with the authorized accessories listed in this manual.
- To ensure proper maintenance, and to avoid all possible damages, only qualified and trained personnel is authorized to perform maintenance work or authorized modifications on the device. The User takes full responsibilities for any dysfunction of the device caused by any maintenance done by any unauthorized person.
- Do not begin treatment if you detect an anomaly with the device.
- Never use the device before making sure that the Air inlet filter is installed.
- WARNING: It is advisable not to use portable RF communicating devices (including peripherals, such as antenna cables as well as external antennas) closer than 30 cm (12 inches) from all parts of the SEFAM S.Box[®] device. This also includes the specified cables by the manufacturer. Should the opposite happen, the performance of these devices could be altered.

In case the device is equipped with a heated humidifier:

- The side cover must be removed and replaced by the humidifier that includes the heater plate and humidifier chamber.
- Precaution must be taken by the patient while using the humidifier chamber in order to prevent any risk of water entering the machine, which can cause irreversible damage. For this purpose, the device must be placed on a horizontal and stable surface, and not in a tilted position.
- The humidifier chamber should always be emptied before moving it with the device or transporting it.

CAUTION:

It means that there is a possibility of material damage to the device or others.

- As this device is an electrical medical device, during its installation, please follow and respect all instructions concerning the electromagnetic compatibility, as indicated in this manual.
- Like all electrical medical devices, the device could experience interferences and disturbances from mobile or wireless radiofrequency communication equipment (Wi-Fi, cell phones or mobile phones...).

Recommended use

The SEFAM S.Box[®] is designed for the treatment of Obstructive Sleep Apnea–Hypopnoea Syndrome (OSAHS) in patients over 30 kg, breathing spontaneously. This device is not intended to provide assistance to vital functions. It can be used at home or in healthcare centers (hospital or clinics). It is also designed for hassle free travelling and can be used on airplanes.

The S.Box heated humidifier is an accessory designed to warm and add moisture to the air flow delivered to the patient by the SEFAM S.Box device, for the treatment of Obstructive Sleep Apnea–Hypopnoea Syndrome (OSAHS). It is intended for use by adult patients in either the homecare or the hospital environment.

NOTE: The EMISSION characteristics of this device allows the machine to be used in industrial zones and in healthcare centres (class A defined in the CISPR 11). When it is used in a residential area (class B defined in the CISPR 11 is normally required), this device may not provide enough protection for communication services with radio frequencies. Users may have to take certain measures, such as the repositioning or the reorientation of the device in order to correct for this.

Contra-indications

Studies have shown that using positive pressure can be contraindicated in certain patients with one of these pre-existing medical conditions:

- Severe bullous emphysema
- Pneumothorax
- Pneumocephalus, trauma or recent surgery with sequela of cranio-nasopharyngeal fistula.
- Decompensated cardiac insufficiency or hypotension, particularly in case of decreased blood volume or cardiac arrhythmia
- Dehydration
- Tracheotomy.

Furthermore, due to the fact that positive pressure affects the cardiac output in certain heart failure patients, it is recommended that patient blood pressure and heart rate are carefully monitored when starting treatment at an effective pressure. The risks and benefits of treatment by Continuous Positive Airway Pressure must be individually evaluated in such subjects. This evaluation must take into account the fact that the device can be adjusted to deliver pressures up to 20 cm H₂O, and under certain defect conditions, static pressures up to 40 cm H₂O are possible. The device must not be used then, if such pressure level presents a risk to the patient.

Essential performance of the device

The essential performance of the SEFAM S.Box[®] is to deliver a pressure equivalent to that of the adjusted pressure ± 0.5 cm H₂O.

The device was designed to maintain basic safety and essential performance without maintenance regarding electromagnetic disturbance during the lifetime of the machine. However, in case of failure the device has to be repaired by authorized persons who will use original parts only.

List of authorized accessories

The SEFAM S.Box[®] product can be used with the following optional accessories:

Description	Reference
SEFAM S.Box	M-116412
S.Box [®] heated humidifier	M-216430-06
S.Box [®] humidifier chamber	M-216430-15
Oximeter 3150	3150-0201
Connectivity:	
S.Box [®] modem	M-116500
S.Box [®] WIFI module	M-116900
Tubings:	
S.Box [®] heated tube	M-216430-07
S.Box [®] Ø 15 mm standard tube	M-261000-05
S.Box [®] Ø 22 mm standard tube	M-261000-06
Travel accessories:	
S.Box [®] carrying bag	M-816405-00
SEFAM S.Box [®] by Starck carrying case	M-816405-01
S.Box [®] cigarette cable (24 VDC-5 m)	M-216430-08
Machine data analysis:	
SEFAM Analyze Software	M-215630-04
S.Box [®] SD card	M-216430-05
S.Box [®] USB cable	M-216430-09
Divers:	
Inlet air filters (50 pcs)	M-315940-01
S.Box [®] Power supply	M-416410-00

WARNINGS:

- Use only the authorized accessories given in the list above or compliant with the standard EN ISO 17510-2:2007.
- Only connect the USB authorized cable to the USB connector. The SEFAM S.Box[®] should not be used if connected via USB to an unauthorized device.
- Use only those accessories which can guarantee the patient's treatment pressure and reduce the re-breathing of CO₂. When a full face mask is necessary, always use a mask which is equipped with an anti-asphyxia valve to maintain spontaneous breathing.
- **WARNING:** Use of this equipment adjacent to or stacked with other equipment should be avoided because it could result in improper operation. If such use is necessary, this equipment and the other equipment should be observed to verify that they are operating normally.
- **WARNING:** Use of accessories, transducers and cables other than those specified or provided by the manufacturer of this equipment could result in increased electromagnetic emissions or decreased electromagnetic immunity of this equipment and result in improper operation.

Features of the device

The SEFAM S.Box® can operate either in constant mode (CPAP), it then delivers a constant pressure level, or automatic mode (Auto-CPAP) where the pressure changes between a minimum pressure and a maximum pressure depending on the detected respiratory events. When selected, the AUTO-CPAP mode will be activated 5 minutes after starting treatment.

Heated humidification

This function allows to control the power supplied to the heater plate depending on the air flow, and to regulate the heating power to maintain the difference in temperature between the water and the air constant. The device is delivered with an installed side cover and depending on the selected configuration, it may be delivered with a heated humidifier which needs installing. In this case, the side cover must be removed from the device and replaced by the humidifier including the heater plate and the humidifier chamber (refer to the patient manual for the setup). The presence of the humidification system is automatically detected by the machine and the heated humidification function starts and stops simultaneously with the device.



Intelligent Start

This feature permits the patient to start the treatment automatically at the first breathings in the mask, without using the start / standby button . It can be activated or deactivated by following the instructions of paragraph "1. Setting menu" page 19.

Mask Fit & Go

Before starting the treatment and when the device is in standby mode, the patient can check the air tightness of his/her mask by using the touch button . The level of unintentional leak is displayed and in case of undesired leak, the patient can adjust his/her mask.

Mask unplugged

When the patient removes his mask, the device automatically switches to low power. The machine will restore normal power when the mask is reconnected (pressure delivered above 3 cm H₂O) or if the start / standby button  or the ramp button  is pressed. If the mask is unplugged for more than 5 minutes, the compliance session is stopped and recorded, and the device will automatically turn off after 30 minutes.

Note:

If the patient uses a resistive interface (nasal pillows mask), a specific calibration of the pneumatic configuration may be performed so that the device can detect that the mask is unplugged (Circuit Select function).

Comfort Control Plus

The Comfort Control Plus CC+ is intended to increase the treatment pressure while inhaling and to decrease it while exhaling to make the patient's breathing more comfortable during the treatment. It can be activated during the ramp or the treatment. In both cases, three levels are available in order to get an optimal comfort.

Ramp function

The ramp function makes it possible to gradually increase the pressure to help the patient fall asleep. If it is activated, it starts automatically when the device is switched on (if the ramp time is different than zero). Pressing the ramp button  deactivates (and by pressing again reactivates) this function. There are two types of ramp:

- T RAMP Time ramp: you can determine the ramp time
- I RAMP Intelligent ramp: the ramp time is automatically determined by the device.

Time ramp

In CPAP mode, the treatment begins at a reduced pressure called Ramp pressure (ramp start pressure), and then the pressure rises up to the prescribed pressure (during the ramp time). If the T Ramp function is deactivated, the pressure increases immediately to the prescribed pressure.

In AUTO-CPAP mode, this function is used to delay the activation of automatic operation (during the latency or ramp time). In the case where the Ramp pressure (ramp start pressure) is less than the minimum pressure, a progressive increase in pressure will be done from the Ramp pressure to the minimum pressure. If the function is deactivated, the pressure remains at the Ramp pressure within the first 5 minutes of treatment and then switches to automatic operation.

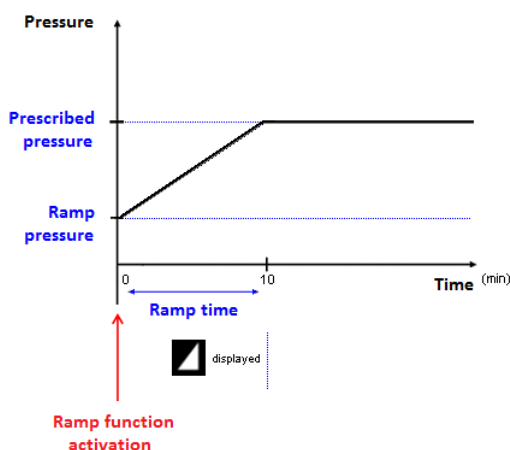

T Ramp function in CPAP mode

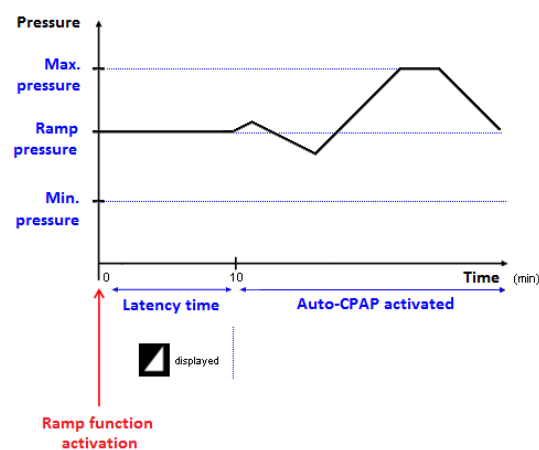

T Ramp function in Auto-CPAP mode

The symbol  is displayed in the status bar and you can adjust the Ramp pressure, the ramp time or latency time and the maximum ramp time (if the Ramp pressure is below the prescribed pressure).

Intelligent ramp

The I Ramp function permits the beginning of the treatment at an adjustable Ramp pressure (ramp start pressure), then a faster increase pressure in the CPAP mode or the activation of the automatic operation in the Auto-CPAP mode as soon as the device starts to detect respiratory events indicating that the patient has fallen asleep.

The symbol  is displayed in the status bar. The I Ramp stops automatically when the maximum ramp time has been reached (45 minutes).

Information and settings

The adjustment of the therapeutic pressure must be determined by the prescribing physician for each patient individually, with the configuration of the equipment to be used, including the accessories. The correct installation and positioning of the patient interface are critical to the proper operation of the device.

WARNING:

Before setting the device, confirm that the product delivers an air flow when it is in operation mode. Otherwise, stop the machine immediately and contact the technical support.

Settings are accessible directly on the interface of the device, via a Bluetooth connection (tablets/cell phones apps), via a configured SD card or remotely through S.Box[®] Wi-Fi module or S.Box[®] modem. You can also adjust the device with the SEFAM Analyze software, by connecting the machine to a computer with a USB cable or a wireless connection.

CAUTION:

The USB connection inhibits automatically any Bluetooth communication.

The most recent compliance data are recorded by sessions in the device memory and on the SD card up to one year for 8 hours of operation per day. They can also be retrieved by wired or wireless connection with the PC software, on the SD card or by modem. Using SEFAM Analyze, you can analyze the compliance data, the use of the device by the patient and the treatment efficiency.

Definitions

Bluetooth, BLE (Bluetooth Low Energy):	low-power, short-range wireless communications technology for connecting devices.
Device hour counter:	device operating time.
Usage hour counter:	total time during which the patient has effectively breathed in the mask (treatment time minus the time when the mask was removed and the time with no respiration).
Ramp pressure (ramp start pressure):	level of pressure produced by the device at the beginning of the ramp function to help the patient fall asleep comfortably. In Auto-CPAP mode, the pressure is reset to the Ramp pressure or the minimum pressure (if the Ramp pressure is lower than the minimum pressure) when no breathing cycle is detected for more than 2 minutes.
Maximum pressure:	maximum pressure that the device can deliver in Auto-CPAP mode.
Minimum pressure:	minimum pressure that the device can deliver in Auto-CPAP mode.
Prescribed pressure:	level of pressure prescribed for the patient.
Humidifier chamber:	chamber containing the water necessary for humidification.
Session:	period during which data is recorded to memory between the time the device starts operation and the time the device goes into standby.
Heating time:	time needed for the device to reach the operating level required by the heated humidification feature.
Ramp time:	time taken by the device to reach the prescribed pressure from the Ramp pressure in CPAP mode or to activate the Auto-CPAP feature when the time ramp is enabled.
Maximum ramp time:	parameter accessible only by the home care provider which restricts

	the maximum value of the ramp time adjustable by the patient when the ramp is activated.
3G:	wireless mobile telecommunication technology for connecting electronic devices.
Wi-Fi:	high-speed wireless transmission technology for connecting electronic devices to one another.

Settings ranges

The following tables indicate the operating mode of the device, the default value, the minimum and maximum values that can be set for each parameter, and the available functions.

Operating mode:

Parameter	Display		By default
Operating mode	CPAP	APAP (Auto-CPAP)	APAP (Auto-CPAP)

Adjustable parameters:

Parameter	Minimum value	Maximum value	Value by default	Increment
Humidification level (if the humidifier is installed)	OFF	10	02	01
Heating power of the heated tube (if installed)	OFF	05	AUTO (with humid.) 01 (without humid.)	01
Mask select: theoretical leak in the mask at 12.0 cm H ₂ O	20 l/min (Type:A)	60 l/min	30 l/min (Type:B)	2 l/min
Ramp time (if T Ramp is selected)	OFF	Maximum ramp time	15 min	5 min
Maximum ramp time (if T Ramp is selected)	OFF	45 min	45 min	5 min
Brightness of the display	01	10	05	01

In CPAP mode:

Set pressure	4 cm H ₂ O	20 cm H ₂ O	8 cm H ₂ O	0.5 cm H ₂ O
Ramp pressure (ramp start pressure)	4 cm H ₂ O	Prescribed pressure	4 cm H ₂ O	0.5 cm H ₂ O

In Auto-CPAP mode:

Ramp pressure (ramp start pressure)	4 cm H ₂ O	Maximum set pressure	4 cm H ₂ O	0.5 cm H ₂ O
Maximum pressure	4 cm H ₂ O or minimum pressure	20 cm H ₂ O	20 cm H ₂ O	0.5 cm H ₂ O
Minimum pressure	4 cm H ₂ O	20 cm H ₂ O or maximum pressure	4 cm H ₂ O	0.5 cm H ₂ O

The device is switched on by holding down the start / standby button . If the heated humidifier is installed, it switches on automatically if the humidification level is set between 01 to 10.

Note:

With a humidification level set to 10, the maximum filled humidifier chamber allows at least 8 hours of use. The rate of water evaporation depends on several factors such as environment, leak rate, patient's breathing pattern, etc.

Available features:

Feature	Activated feature	Deactivated feature	By default
Bluetooth	BT: ON	BT: OFF	BT: ON
Comfort Control Plus CC+	CC+: R.1, R.2 or R.3 (during the ramp)	CC+: OFF	CC+: OFF
	CC+: 1, 2 or 3 (during the treatment)		
Modem connection	3G: ON	3G: OFF	3G: ON
PolyLink connection	BLE: ON	BLE: OFF	BLE: ON
Wi-Fi connection	WIFI: ON	WIFI: OFF	WIFI: ON
Intelligent Start	IS: ON	IS: OFF	IS: ON
Ramp	T RAMP (Time ramp)	OFF	I RAMP
	I RAMP (Intelligent ramp)		
Locking access to a group of three settings by the patient (Ramp pressure, CC +, Intelligent Start)	LOCK (locked access)	UNLOCK (unlocked access)	UNLOCK (unlocked access)

Note:

The connection to the PolyLink system, the S.Box[®] modem or the Wi-Fi module will operate only when the corresponding accessory is installed in the device.

Circuit Select (pneumatic calibration):

Used patient circuit	Length: 1,80 m Diameter: 15 mm (Heated tube included)	Length: 1,80 m Diameter: 22 mm	Other	By default
Display	15	22	CS	15



Note:

As the device is equipped with a differential pressure sensor, the pressure level is automatically compensated for altitude.

User interface description

The two mechanical buttons on the top of the device are used to manage its operation:

- Start / standby button  : to switch the device on or off.

- Ramp button : to disable or enable the ramp feature when the device is in use. If it is pressed simultaneously with the touch key , it also allows you to access your specific settings menu. The touch screen areas located on the front side permit to access the information and the settings menus of the device, and eventually, change the value of certain parameters. The parameters are accessible by various touch keys:
 - the settings concerning the treatment of the patient,
 - the recorded compliance data,
 - the general settings of the device like the brightness and the time.
 The display can also notify possible problems concerning the device or its accessories.

General organization of display

From top to bottom, the display is structured in three zones:



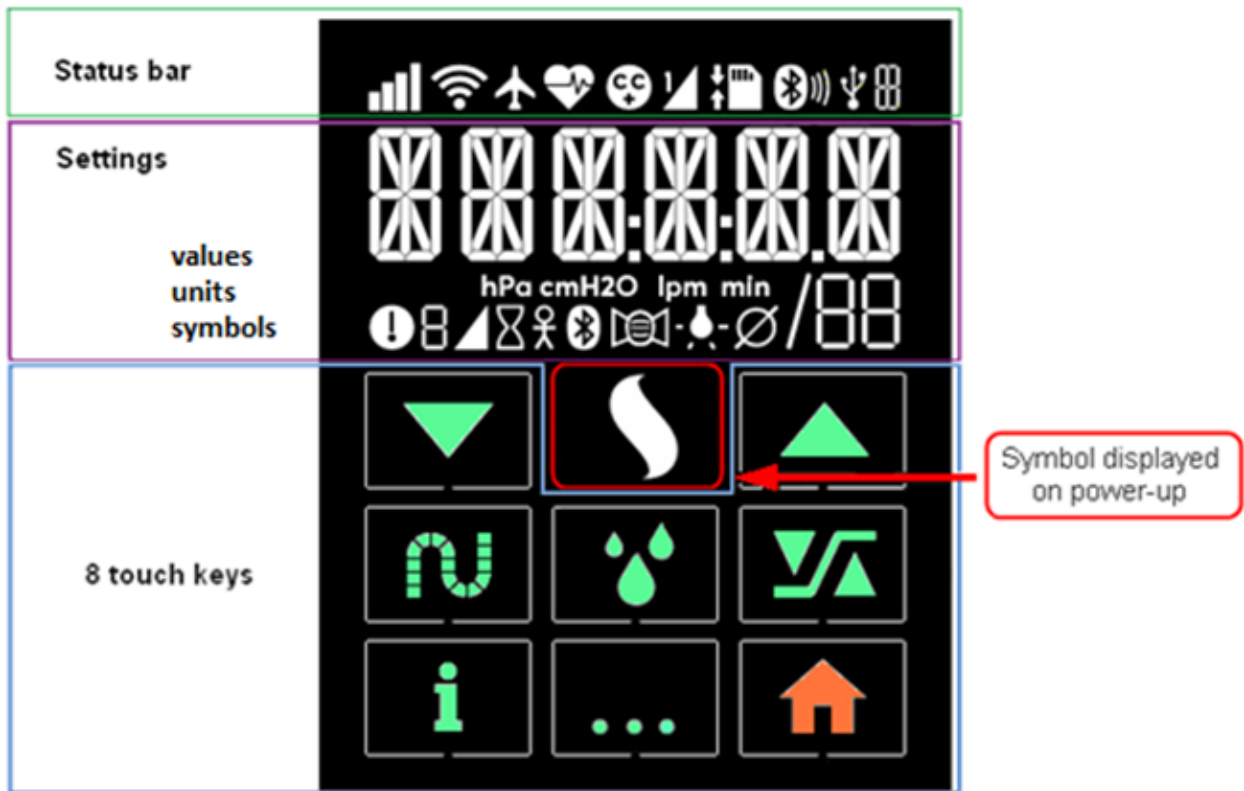











- a status bar
- a settings zone
- an area with 8 touch keys and the 'S' symbol displayed when the device is switched on.

















Notes:

- The backlight of the display is activated when you approach your hand (Wave & Go function) or by tapping a touch key or one of the two operating buttons located at the top of the device.
- The displays used in this manual are given as examples.







Description of symbols

Symbol	Meaning	Symbol	Meaning
Status bar			
	GSM mobile phone network status. Flashes quickly during the transmission.		Wi-Fi Communication activated. Flashes quickly during the transmission.
	Airplane mode		Oximeter connected
	Comfort Control Plus C.C.+ function activated		Time ramp T RAMP activated
	SD card inserted		Intelligent ramp I RAMP activated
	↓ Flashes slowly when data storing is in progress.		Bluetooth connection activated
	↑ Flashes slowly when settings update is in progress.		Bluetooth transmission in progress
	USB connection activated		Operation mode C: CPAP
			A: APAP (Auto-CPAP)

Settings: values, units and symbols displayed



	Numbers or letters		Pressure unit: hecto Pascal or cm H ₂ O
	Flow unit: liter per minute		
	Caution: the device detected an error or an incident		Time unit: hour and minute
	Machine hour counter		
	Bluetooth		Setting of the ramp time
	Setting of the brightness of the display		Usage hour counter
			Mask adjustment
			Diameter of tube





Touch keys

	Scrolling-down touch key, allows to decrease the value of the displayed parameter		Scrolling-up touch key, allows to increase the value of the displayed parameter
	Touch key to adjust the S.Box heated tube with ATC setting		Touch key to adjust the heated humidifier setting
	Touch key to access the settings		Touch key to access information
	Multifunctional touch key		Home touch key

How to set the device



1. Setting menu



The adjustment of the treatment parameters is accessible by the touch keys displayed on the screen. The access to some of them is restricted to the medical professional (in standby mode only). In this case, press and maintain the ramp button , then tap the touch key  for two seconds when it is shown on the display. In the settings sequence:

- tapping the touch key  or  permits to decrease or increase the value of the parameter, make changes, deactivate or activate the displayed function,
- tapping the touch key  permits to access the next display,
- maintain the ramp button  pressed, then tapping the touch key  permits to return to the previous display,



The standby screen is restored by tapping  or after two minutes without tapping a key.

Views of the display:



1
Press and hold the ramp button  then tap the touch key  for two seconds in standby mode.

Mode of operation
You can change the displayed mode by tapping the key  or .
Possible settings: CPAP or APAP (Auto-CPAP).

2
Tap the touch key 

Maximum pressure if the APAP (Auto-CPAP) mode was selected.
You can decrease or increase the displayed value by tapping repeatedly the key  or .
Possible settings: from the minimum pressure to 20 cm H₂O.

Tap the touch key 

Minimum pressure if the APAP (Auto-CPAP) mode was selected.
You can decrease or increase the displayed value by tapping repeatedly the key  or .
Possible settings: from 4 cm H₂O to the maximum Pressure.



or



2
Tap the touch key



Views of the display:



Pressure level if the CPAP mode was selected.



You can decrease or increase the displayed value by tapping repeatedly the key  or .

Possible settings: from 4 cm H₂O to 20 cm H₂O.

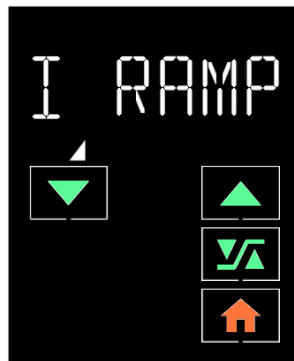
3
Tap the touch key



Ramp selection



You can change or deactivate the selected ramp by tapping the key  or .

Possible settings: I RAMP, T RAMP and OFF.

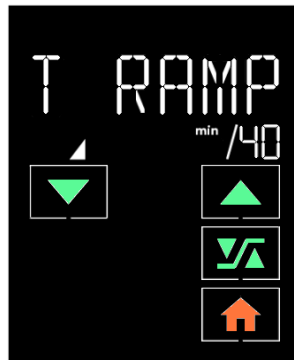
or



If you selected T RAMP Time ramp the displayed value on the right corresponds to the maximum ramp time.

You can decrease or increase the displayed value by tapping repeatedly the key  or .

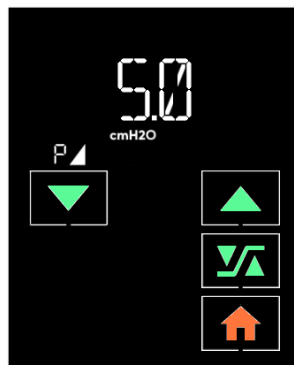

Possible settings: from 5 to 45 minutes.

4
Tap the touch key



Ramp pressure (ramp start pressure)

In CPAP mode, this setting is displayed only if the ramp was selected (ramp ≠ OFF).

You can decrease or increase the displayed value by tapping repeatedly the key  or .

Possible settings:

- from 4 cm H₂O to the maximum pressure adjusted in APAP mode (Auto-CPAP).
- from 4 cm H₂O to the prescribed pressure in CPAP mode.

5
Tap the touch key



Views of the display:

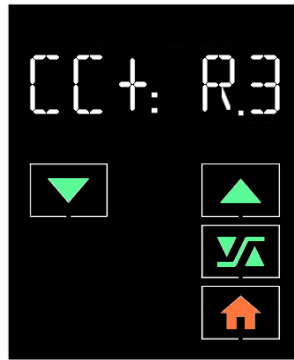

CC+ (Comfort Control Plus)

You can change or deactivate the selected function by tapping the key  or  as many times as necessary.



Possible settings:

- during the ramp (R.1, R.2, R.3)
- during the entire treatment (1, 2, 3)
- deactivating: OFF.

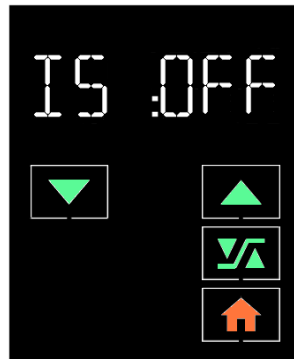
6
Tap the touch key



IS (Intelligent Start)



You can activate (ON) or deactivate (OFF) this function by tapping the key  or .

Possible settings: ON and OFF.

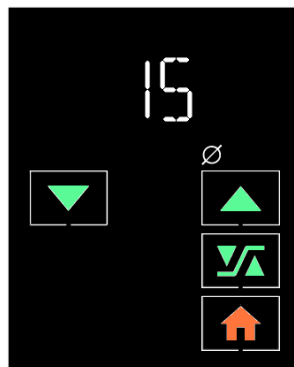
7
Tap the touch key



Circuit Select (pneumatic calibration)

Tapping repeatedly the touch key  or , you can choose the pneumatic calibration adapted to the pneumatic circuit (tube and mask) of the patient.

Possible settings:

- 15 (tube 15 mm in diameter)
- 22 (tube 22 mm in diameter)
- CS (Circuit Select).

or

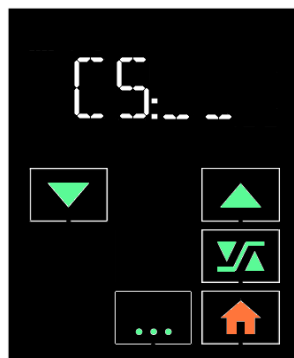

If you select Circuit Select CS, the touch key  is displayed on the screen. Tap it to run the specific calibration.

Tap the touch key



Views of the display:





A progress bar indicates the status of the calibration until the specific calibration is effective and confirmed on the display.

Refer to paragraph "5. Circuit Select: specific calibration of the pneumatic configuration" page 22.

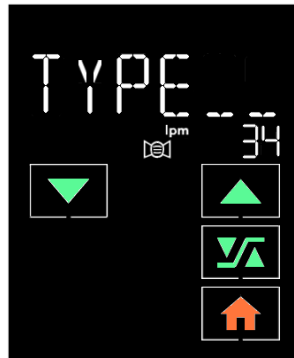
8 Tap the touch key



Mask select: theoretical leak in the mask

You can enter the value of the theoretical leak in the mask at 12 cm H₂O (given in the corresponding instructions for use of the mask) by tapping the touch key  or  as many times as necessary.

Possible settings: from 20 to 60 lpm by steps of 2 lpm.

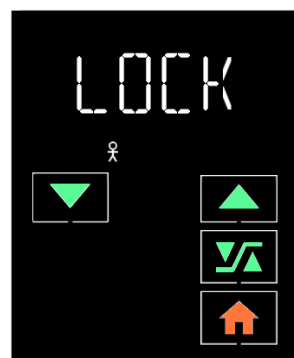

Three possible types of masks: A, B and C (refer to the corresponding list).

9 Tap the touch key



Locking access to the group of three following settings by the patient:

- Ramp pressure
- CC + Comfort Control Plus
- IS Intelligent Start.

You can lock (or unlock) access by patient to these three settings in selecting LOCK (or UNLOCK) by tapping the touch key  or .



Possible settings: LOCK and UNLOCK.

10 Tap the touch key



Choosing the format of time display

The time display is set to 24 hours by default.

You can select another format by tapping the key  or .



Possible Settings: 24H and 12H.

Views of the display:

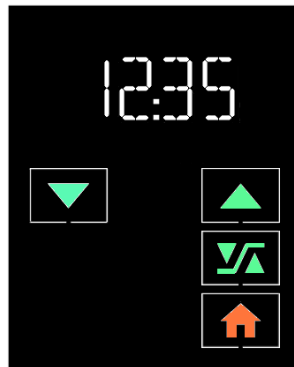
11
Tap the touch key

Clock

The hour blinks on the display. You can set it by tapping the touch key  or  as many times as necessary.



Tap .

The minutes blink. Adjust the minutes the same way as the hour.

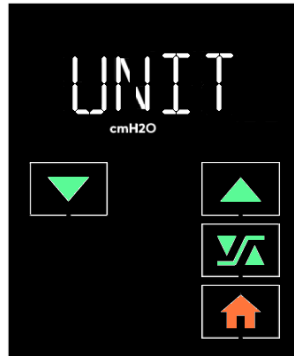
12
Tap the touch key

Pressure unit

You can change the unit of the displayed pressure by tapping the touch key  or .

Possible settings: cm H₂O and hPa.

13
Tap the touch key



Offset of the pressure and flow sensor

The touch key  visible on the screen permits to run an automatic calculation of the offsets of the sensors. It is also possible to read the offset values of the pressure and flow sensor.

Tap the touch key





The offset value of the **pressure sensor** is displayed approximately two seconds later.

Unchangeable value: from 1500 to 2500 (default value 2000).

If a offset problem occurs on the pressure sensor, the value is no longer displayed :

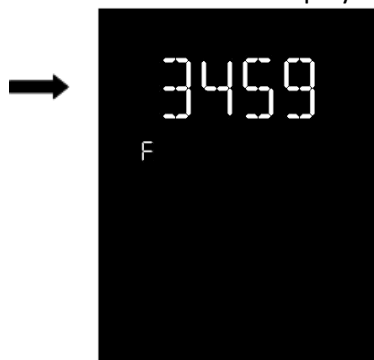

Views of the display:



The offset of the flow sensor comes after. Unchangeable value: from 1450 to 5450 (default value 3450). If a offset problem occurs on the flow sensor, the value is no longer displayed :



14 Tap the touch key

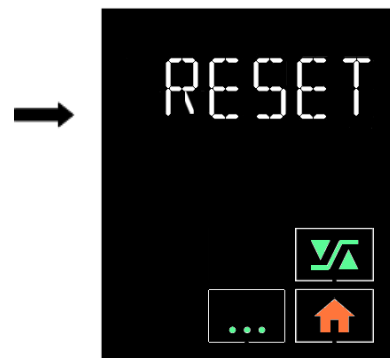

Delete of data

The touch key visible on the screen permits, if you wish, to restore the FACTORY configuration of the device.

CAUTION:

Restoring the FACTORY configuration erases all of the data recorded in the device and on the SD card, as well as the pairing with the installed communicating accessory.

Tap the touch key

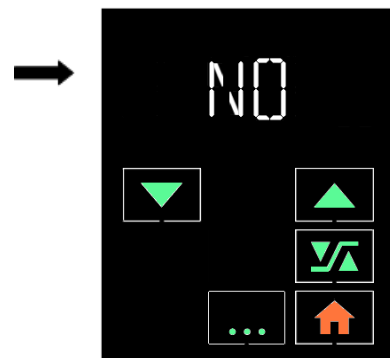

Tapping the touch screen or , you can choose:

- YES to go back to the factory configuration
- NO if you wish to keep all data and the pairing of accessories.

15 Tap the touch key

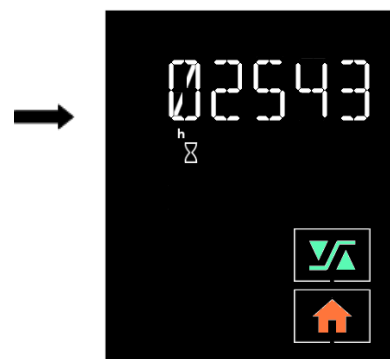

Total machine hour counter

This counter calculates the operating time of the device.

16
Tap the touch key



Views of the displays:

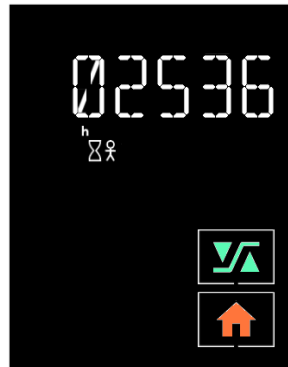

Total usage hour counter

This counter calculates the time during which the patient has breathed into the mask.

17
Tap the touch key

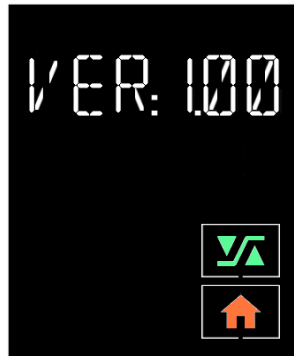













Software version

This is the version of the embedded software of the device. It can be read but not written.

Tap  to exit the menu.

2. Settings accessible to the patient







The patient can access a settings menu of the device in standby mode (see patient manual). He/she can also make the following adjustments using the touch keys displayed:

Tap	Displayed parameter:	Adjusted by	Available displays:
 in standby or operating mode	 Heating power of the heated tube (when S.Box heated tube with ATC installed)	 or 	OFF, 01 to 05 and AUTO (if humidifier installed)
 in standby or operating mode	 Humidification level (when humidifier installed)	 or 	OFF, 01 to 10
 in standby mode	 Mask Fit & Go: controls air tightness of the mask	Readjustment of the mask	LK: OK, LK: NOK
 in operating mode	 Display of the clock during the treatment		Return to the delivered pressure

Tap  to exit the display.

3. Information menu

The touch key  gives access to the compliance information recorded in the device during the last 24-hour periods stored (within the limit of 30 days), then to the technical information about the device (see patient manual).

Tap	Information displayed successively:
 in standby mode	→ Accessing a period of use
	→ Selecting one of the last memorized periods of use
	→ Accessing the compliance information report for the period of use
 each time you go to the next display	→ Average level of unintentional leakage in the mask
	→ Usage hour counter
	→ Average pressure delivered
	→ Index of obstructive Apneas and Hypopnoeas
	→ Index of central Apneas
	→ Number of the last days of use for which the compliance has been higher than 4 hours per day (when the number of the last days of use is more than 1 and within the limit of 30 days)
	→ Accessing technical information concerning the device
 each time you go to the next display	→ Identification number specific to the patient
	→ Software version
	→ Total usage hour counter
	→ Total machine hour counter

Tap  or  to exit the menu.

4. Pairing a Bluetooth device

When you are using **Sefam ACCESS Pro** application or **SEFAM Analyze** software on a Bluetooth enabled device (such as a Smartphone or a tablet) and you connect it to the SEFAM S.Box in standby mode via Bluetooth wireless communication, a message appears on the display of the machine at the first pairing:

View of the display:

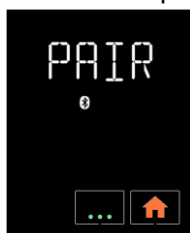

Tap the touch key



or



→ Enable pairing

→ Refuse to pair

The display disappears after 30 seconds.

5. Circuit Select: specific calibration of the pneumatic configuration

The specific calibration function of the pneumatic circuit permits to adjust the pressure delivered to the mask with a high level of accuracy by compensating for all the pneumatic resistances in the patient circuit. It makes it possible to adapt any type of pneumatic resistance generated by a breathing tube, a mask or any accessory that can be connected in between the patient and the device.

CAUTION:

Since the pressure performance is depending on the selected pneumatic configuration, it is important to select the proper configuration. In the case of a specific configuration, this operation must be performed by qualified personnel only.

To optimize the performance of the device, it is advisable to carry out a specific calibration depending on the pneumatic configuration.

1. Make sure the unit is in standby mode. If it is in operation, stop it by pressing down the start / standby button  for a few seconds.
2. Install the desired pneumatic configuration (breathing tube, filter, etc...) with the patient interface (e.g. mask). Make sure to keep the respiratory circuit straight and outlet free.
3. Refer to paragraph "1. Setting menu" page 14 to access the successive displays, until the pneumatic calibration appears.

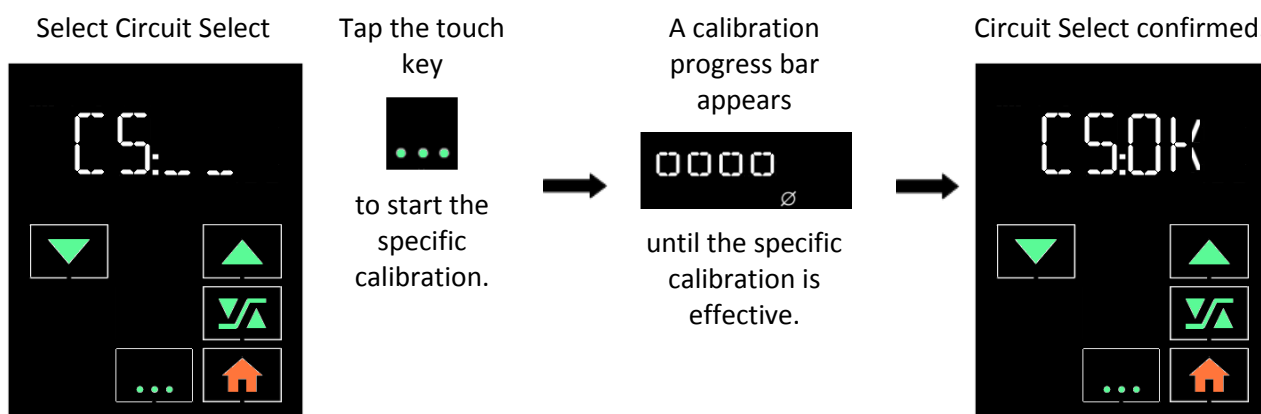

Do not touch the pneumatic circuit while the device is performing the calibration. The message "CS: OK" informs that the calibration was done properly.

Tap  to exit the settings menu.

Using the SD card

The SD card permits to store the most recent compliance data or to update the device settings.

Saving data

Each time the treatment is stopped, the most recent compliance data memorized by the device are automatically saved on the SD card.

The memory card can also store the signals acquired in real time for about 3 months. For this purpose, a memory card has to be inserted in the device while using it.

Once the data is saved, the patient can send the memory card to you and you will retrieve the compliance data and analyze it using the SEFAM Analyze software.

Then, insert the SD card in the memory card reader of your computer. To retrieve the compliance data, refer to the user manual of the SEFAM Analyze software.

CAUTION:

Use only authorized SD cards.

Settings update

You can adjust the settings of a device by following the instructions given by the SEFAM Analyze software, and save them on the SD card. An update of the device settings starts automatically when the patient inserts the card for the first time.

Service card

A SD card can be configured as a "service card" using the SEFAM Analyze software, in order to set up a collection of devices with the same default parameters. This allows adjusting only the parameters specific to the patient. To configure a "service card", refer to the user manual of the SEFAM Analyze software.

To use the service card with the device, hold down the button  while inserting the card.

Cleaning and maintenance

Make sure that the patient follows carefully the instructions given in this chapter.

The patient should refer to the user guide for instructions on maintenance for the mask, the breathing tube, the S.Box heated tube with ATC and the communicating accessory.

WARNING:

Unplug the device from the power supply. Always remove the breathing tube and the humidifier chamber from the device before cleaning.

CAUTION:

- For cleaning, only use materials suited for this purpose.
- Do not use aggressive detergent, scouring sponge or hard bristle brush.

Daily

Humidifier chamber (if humidifier is installed):

- Remove the humidifier chamber:
 - To remove the humidifier chamber from the device, press the button to unlock the humidifier chamber and at the same time, pull the humidifier chamber using the integrated handle.
 - Put the humidifier chamber away from the device and pull the opening clip upwards to release the upper part of the chamber. Empty the water if any.
- Rinse with clean water.
- Allow to dry by draining, away from the sun.
- Re-install the humidifier chamber, once it is dry.
 - Fill the bottom part of the humidifier chamber, then press down on the upper part to close the chamber and lock it.
 - Place the humidifier chamber back on the heater plate, hinge side towards the inside of the machine, and push it against the device until you hear a "click".

Weekly

Humidifier chamber (if humidifier is installed):

- Remove the humidifier chamber:
 - To remove the humidifier chamber from the device, press the button to unlock the humidifier chamber and at the same time, pull the humidifier chamber using the integrated handle.
 - Put the humidifier chamber away from the device and pull the opening clip upwards to release the upper part of the chamber. Empty the water if any.
- Clean the different parts of the chamber with warm water and a mild detergent (e.g. using 3 drops of dishwashing liquid diluted in water).
- Rinse thoroughly with water to remove any trace of detergent.
- Allow to dry by draining, away from the sun.
- Re-install the humidifier chamber, once it is dry.
 - Fill the bottom part of the humidifier chamber, then press down on the upper part to close the chamber and lock it.
 - Place the humidifier chamber back on the heater plate, hinge side towards the inside of the machine, and push it against the device until you hear a "click".

Notes:

- The different parts of the humidifier chamber can also be cleaned in a dishwasher (maximum 70 ° C).
- Do not leave stagnant water in the chamber in order to prevent the development of micro-organisms.

Washable filter:

- Remove the air intake grid.
- Pull the filter towards you to remove it.
- Wash the filter with lukewarm water and a mild detergent (e.g. using a drop of dishwashing liquid diluted in water).
- Rinse thoroughly to remove any trace of detergent.
- Drying the filter: press the filter in a clean absorbent cloth, then, let it dry totally away from the sun.
- Once dried, place the filter at the back of the device and put back the air intake grid. Do not use a partially dry filter.

Monthly

Device:

- Clean the outside of the device with a damp cloth (rag, paper towel) sprinkled with a little water and a drop of mild detergent.
- Remove traces of detergent by repeating this procedure with a new cloth, (rag, paper towel) slightly moistened with only water.
- Wipe the device completely dry with a dry cloth (rag, paper towel).

Air inlet filters:

- The optional fine filter cannot be washed. It must be changed once a month or more, if it is visibly dirty.
- Change filters as soon as they are torn or stained.
- It is recommended to change the washable filter every 6 months.

Humidifier (if installed):

- Once the humidifier chamber has been cleaned, the patient can let it soak for 15 minutes in a solution of 9 volumes of water and one volume of white vinegar.
- Rinse thoroughly with water to remove any trace of vinegar.
- Allow to dry by draining, away from the sun.
- When the humidifier chamber has been removed and emptied, the heated plate can be cleaned by following same cleaning procedure as the device. Reinstall it once it is dry.
- Put the humidifier chamber back in place.
 - Fill the humidifier chamber, then press down on the upper part to close the chamber and lock it.
 - Place the humidifier chamber back on the heater plate, hinge side towards the inside of the machine, and push it against the device until you hear a "click".

WARNINGS:

- Check if the heater plate is properly dried before plugging the device.
- Never use the device without making sure that the air inlet filter is present.
- Do not use spray detergent. Harmful residues could enter and remain in the air outlet, the air inlet filter or inside of the device, which could cause air way irritation.
- Never use concentrated bleach higher than 0.1%. For example: pour 200 ml of bleach to 2.6% in 5 liters of cold water.

Disinfecting the materials

Please refer to the instructions for use of the chemicals you use in order to comply with dilution and quantity of products, contact time and wearing of personal protective equipment.

Disinfecting the surface of the device

Disinfecting the outside of the device is done with disinfectant detergents.

- If using a spray or foam disinfectant detergent:
 - Spray the product on a non-woven disposable cloth or tissue
 - Wipe the outside of the device with this cloth or tissue and let it dry.
- If using disinfectant detergent wipes:
 - Wipe the outside of the device and let it dry.

Disinfecting the humidifier chamber (if humidifier is installed)

The humidifier chamber is prescribed to be used by one patient only at home or several times in a Medical Care Center.

- Remove the humidifier chamber from the device and disassemble it completely.
- Pre-disinfection:
 - Submerge the parts of the humidifier chamber completely in the pre-disinfectant solution diluted according to the instructions recommended by the manufacturer of the pre-disinfectant.
 - Likewise, respect the recommended soaking time and, if necessary, brush with a soft brush.
 - Rinse carefully and thoroughly all parts of the chamber with running water.
- Cleaning:
 - Prepare a soaking container with water and mild detergent (e.g. using 5 to 10 ml of dishwashing liquid diluted in 5 liters of water).
 - Clean the parts of the humidifier chamber in the detergent solution and, if necessary, brush with a soft brush.
 - Rinse carefully and thoroughly the different parts of the humidifier chamber under running water.
 - Remove the excess water by slightly shaking it.
- Disinfection:
 - Prepare a new soaking container with water and disinfectant.
 - Follow the same steps as for pre-disinfection.
- Drying:
 - Let it drain out away from the sun.
- Storage:
 - Reassemble the humidifier chamber.
 - Keep the disinfected and dried humidifier chamber in a clean, single-use, hermetically sealed bag until its next use.

Note:



Dispose of the humidifier chamber when it is damaged and replace it with a new one.

Things never to use





- Never use abrasive or strong alkaline cleaners, acetone, benzene, leaded gasoline to clean the device.
- Do not use a type of sponge with a scraper or a hard bristle brush.
- Never use any pre-disinfectant or disinfectant products containing Aldehydes and/or its derivatives: Formaldehyde, Glutaraldehyde, etc.
- Do not use pre-disinfectant or non-active disinfectant on Mycobacterium tuberculosis (B.K).
- Never disinfect the internal circuit of the air flow with disinfectant or with an Airway Surface Disinfection System (ASDS).

Troubleshooting tips

Device Messages

Message on the display	Possible cause	Proposed solution
	The mask is disconnected.	Check the connection between the mask, the breathing tube and the device. This message disappears once you breathe into your properly reconnected mask or press the  or  button.
 This symbol flashes on screen.	The device detected an operating error in the heated humidifier.	The device is operating without the heated humidification function. The corresponding error code is registered in the memory of the machine and is accessible by using the SEFAM Analyze software. Refer to the section "Error messages".
 This symbol flashes on screen.	The device has detected a malfunction of the S.Box heated tube with ATC.	The device is operating without using the function of the heated tube. Check the tube connections to the device. Unplug the device from all power sources. Plug it in again and turn it on. If the problem persists, contact Technical Support Service.
The symbol  flashes quickly on the status bar display.	<p>The SD card is either not inserted or not properly inserted in the device.</p> <p>The SD card is locked.</p> <p>The SD card is 90% full, or more.</p> <p>SD card error.</p>	<p>Insert the SD card properly into the SD card slot.</p> <p>Unlock the SD card and reinsert it into the SD card slot.</p> <p>Delete files on the SD card and give it back to the patient.</p> <p>Give a new SD card to the patient.</p>
 <p>The error code flashes. (XX = 2 figures).</p>	The unit detected an operating error.	Refer to the section "Error Messages".

Error Messages

Code	Description	Corrective action
ER01	Problem with patient settings.	Reset the default settings by pressing the ramp button  for 2 seconds, then the scroll up using touch key  . The message  will blink. Tap scroll up touch key  to confirm. The device is now set at default values. You can begin to make the settings you wish to. If the error persists, return the device to Technical Support service.
ER02	High temperature in the motor	Unplug the device from all power supply. Allow it to cool down and plug it in again following carefully the instructions from the patient manual. If the error persists, return the device to Technical Support service.
ER03	Memory battery full.	Unplug the device from all power supply. Plug it in again. If the error persists, return the device to Technical Support service.
ER04	High pressure	Unplug the device from all power supply. Plug it in again. If the error persists, return the device to Technical Support service.
ER06	Checksum code error.	Unplug the device from all power supply. Plug it in again. If the error persists, return the device to Technical Support service.
ER07	Turbine problem.	Unplug the device from all power supply. Verify that there is no object in the air outlet. Plug the machine in again. If the error persists, return the device to Technical Support service.
ER08	Voltage level problem	Unplug the device from all power supply. Plug it in again. If the error persists, return the device to Technical Support service.
ER10	Device set-up problem	Unplug the device from all power supply. Plug it in again. If the error persists, return the device to Technical Support service.
ER11	High motor current consumption	Unplug the device from all power supply. Plug it in again. If the error persists, return the device to Technical Support service.
ER12	Device memory is empty.	Unplug the device from all power supply. Plug it in again. If the error persists, return the device to Technical Support service.
ER13	Communication error on the I ² C bus.	Unplug the device from all power supply. Plug it in again. If the error persists, return the device to Technical Support service.

Notes:

- When an error is detected, the device goes in standby mode (except for special cases) making access to different menus impossible.
- Error codes can be processed using the SEFAM Analyze software or the tablets/Smartphones apps.

Technical characteristics

Performance of the device

Pressure range:	4 cm H ₂ O to 20 cm H ₂ O Adjustable by steps of 0.5 cm H ₂ O
Maximum pressure at the patient-side connection port in the first default condition:	40 cm H ₂ O
Maximum adjustable pressure:	20 cm H ₂ O
Duration of ramp:	0 to 45 minutes ± 1 minute Adjustable in 5 minute steps
Sound pressure level measured according to standard NF EN ISO 17510-1: 2009:	27.5 dBA with side cover 28.5 dBA with humidifier
Patient-side connection port:	conical connector 22 mm in diameter
Battery life in electronic board:	5 years
Air inlet filters:	Optional high-efficiency filter, disposable fabric. HEPA filter, which is 90% effective for particles > 3 microns.

Values determined under ATPD (Ambient Temperature and Pressure, Hygrometry) conditions.

Time required for the device to warm from the minimum storage temperature between uses until it is ready for its intended use when the ambient temperature is 20°C:	At least one hour
Time required for the device to cool from the maximum storage temperature between uses until it is ready for its intended use when the ambient temperature is 20°C:	At least one hour

Humidifier performance

Humidification rate:	> 12mgH ₂ O/l at the maximum setting for a leakage rate < 60 l/min.
Heating time:	45 minutes
Pressure drop depending on flow:	1.3 cm H ₂ O at 1 l/sec
Humidifier chamber compliance:	11 ml / kPa (humidifier chamber empty) 8 ml / kPa (humidifier chamber full)
Maximum operating pressure:	20 cm H ₂ O
Maximum gas temperature coming from the respiratory circuit:	43°C

Values determined under ATPD (Ambient Temperature and Pressure, Hygrometry) conditions.

Conditions of use

Pressure range:	700 hPa to 1060 hPa
Temperature:	+5°C to +40°C with side cover +5°C to +35°C with humidifier
Relative humidity:	Between 15 % and 90 % without condensation
Altitude range:	Approximately 0 – 2 500 m

Transport and storing conditions

Pressure range:	700 hPa to 1060 hPa
Temperature:	-25°C to +70°C
Relative humidity:	Up to 90 % without condensation

Electrical characteristics

Device

Input voltage:	24.0 V \pm 20 %
Maximum power consumption:	75 W during a mask disconnection
Current consumption at 20 cm H ₂ O with a 4-mm leak:	0.42 A (minimum configuration: SEFAM S.Box only) 1.99 A (maximum configuration: SEFAM S.Box with humidifier set to 10 and heated tube set to 05)

RF emission type (SEFAM S.Box®):	Bluetooth version 2.1+ EDR
Frequency band:	2400 to 2483.5 MHz (ISM band)
Maximum power:	4 dBm

RF emission type (PolyLink):	Bluetooth Smart (BLE 4.1)
Frequency band:	2402 to 2480 MHz (ISM band)
Maximum power:	5.3 dBm

RF emission type (optional S.Box® Modem):	HSDPA, WCDMA, EDGE, UMTS
Frequency band:	850MHz, 1900 MHz (for US version) 900MHz, 2100MHz (for European version) 800MHz, 850MHz, 2100MHz (for Japanese version)
Maximum power:	+33 dBm

RF emission type (optional S.Box® Module Wi-Fi):	Wi-Fi 802.11b/g/n
Frequency band:	2412 to 2484 MHz (ISM band)
Maximum power:	+18 dBm

Power supply

Power supply class II:	
Input voltage:	100 – 240 VAC, 50 - 60 Hz
Power supply provided:	MDS-090BAS24 A (outlet depending on the country)
Input current:	2 - 1 A
Output voltage:	24 V

WARNING:

- Use only the plug-in power supply provided with the device
- The power supply is not intended to be repaired. In case of a breakdown, please contact your home care provider for a replacement.
- The 24 V_{DC} input is protected against voltage reversals.
-

Physical characteristics

Dimensions (L x W x H):	245 x 140 x 110 mm with side cover 245 x 185 x 110 mm with humidifier
Carrying bag dimensions (L x W x H):	305 x 245 x 180 mm
Carrying case dimensions (L x W x H):	350 x 310 x 190 mm
Weight (without power supply):	1.4 kg with side cover 1.7 kg with humidifier
Power supply weight:	0.5 kg
Operational volume (minimum volume of gas in the humidifier chamber):	730 ml
Usable volume of water in chamber	350 ml
Maximum liquid level:	Indicated by ↑ MAX ↑ on humidifier chamber

Definition of symbols

Symbol	Description	Symbol	Description
	Start / standby button.		Ramp button.
	Device is in accordance with the requirements of the European directive 93/42 /EC on medical devices.		Device can no longer be used, dispose separately from household garbage. See "End of life disposal of the device" page Erreur ! Signet non défini..
	Class II device.		Type BF device.
	24 V Direct Current power supply		Device composes an RF transmitter, non - ionizing radiation.
	Manufacturer.		Manufacturing date.
	Danger: hot surface.		On the humidifier chamber, this symbol indicates the maximum water level which should not be exceeded in the chamber.
	On the humidifier chamber, this symbol indicates that it is necessary to open the chamber and remove its cover before pouring water in from a recipient.		Do not pour water directly into the openings of the humidifier chamber.
	On the heater element, this symbol indicates in which direction to push the latch to lock or unlock the heater plate.		Device protected against solid objects of more than 12 mm and against drops of water falling vertically.
	On the packaging, this symbol means "Atmospheric pressure limit".		On the packaging, this symbol means "Relative humidity limit".



On the packaging: this symbol means "Fragile" because the package must be handled with care.



On the packaging: this symbol means "Keep dry" because the package must be protected against moisture and water.



On the packaging, this symbol means "Temperature limit".



Refer to the user manual.

CE marking

Date of CE marking of SEFAM S.Box®: 2017

Regulatory Requirements

Risks concerning this medical device are evaluated according to the ISO 14971 standard, specifically with regard to global residual risk.

The SEFAM S.Box® complies with the following Directives and standards:

- Directive 93/42/CEE of the European Parliament and of the Council concerning medical devices, modified by the European Directive 2007/47/CE
- Directive 2014/53/EU of the European Parliament and of the Council on the harmonization of the laws of the Member States relating to the making available on the market of radio equipment
- Directive 2011/65/EU of the European Parliament and of the Council on the restriction of the use of certain hazardous substances in electrical and electronic equipment (RoHS)
- Directive 2012/19/EU of the European Parliament and of the Council on waste electrical and electronic equipment (WEEE)
- Federal Aviation Administration RTCA/DO-160G section 21 category M
- IEC 60601-1:2005 + AC1:2006 + AC2:2007 + Amd1:2012: Medical electrical equipment. Part 1: General requirements for basic safety and essential performance
- IEC 60601-1-2:2014: Medical electrical equipment – Part 1-2: General requirements for basic safety and essential performance – Collateral Standard: Electromagnetic disturbances – Requirements and tests
- IEC 60601-1-2:2015: Medical electrical equipment – Part 1-2: General requirements for basic safety and essential performance – Collateral Standard: Electromagnetic disturbances – Requirements and tests
- ISO 80601-2-70-1:2015: Medical electrical equipment -- Part 2-70: Particular requirements for basic safety and essential performance of sleep apnea breathing therapy equipment
- EN ISO 8185:2009: Respiratory tract humidifiers for medical use -- Particular requirements for respiratory humidification systems

End of life disposal of the device

In European Union this device has to be considered as an electrical and electronic piece of equipment as defined in Directive 2012/19/EU, and must be collected and processed separately from household waste for disposal as indicated by the symbol of the crossed out garbage bin (see "Definition of symbols").

In other countries, this device must be processed following local regulation.

Unsuitable disposal of the device at the end of its life could harm the environment.

Electromagnetic Compatibility

Electromagnetic emissions	Conformity	Electromagnetic environment guidance
RF emissions CISPR 11	Group 1 Class B	The device uses RF energy only for its internal function. Therefore, its RF emissions are very low and are not likely to cause any interference in nearby electronic equipment.
Harmonic emissions IEC 61000-3-2	Class A	
Voltage fluctuations/Flicker emissions IEC 61000-3-3	Complies	

Electromagnetic Immunity	Test level	Compliance level	Electromagnetic environment guidance
Electro-static discharge (ESD) IEC 61000-4-2	± 6 kV contact ± 8 kV air	± 6 kV contact ± 8 kV air	Floors should be wood, concrete or ceramic tile. If floors are covered with synthetic material, the relative humidity should be at least 30 %.
Electrical fast transient/burst IEC 61000-4-4	± 2 kV for power supply lines ± 1 kV for input / output lines	± 2 kV for power supply lines ± 1 kV for input / output lines	Mains power quality should be that of a typical commercial or hospital environment.
Surge IEC 61000-4-5	± 1 kV lines/lines ± 2 kV lines/earth	± 1 kV lines/lines ± 2 kV lines/earth	Mains power quality should be that of a typical commercial or hospital environment.
Voltage dips, short interruptions and voltage variations on power supply input lines IEC 61000-4-11	< 5% UT (>95% dip in UT) for 0.5 cycles 40% UT (60% dip in UT) for 5 cycles 70% UT (30% dip in UT) for 25 cycles < 5% UT (>95% dip in UT) for 5 s	< 5% UT (>95% dip in UT) for 0.5 cycles 40% UT (60% dip in UT) for 5 cycles 70% UT (30% dip in UT) for 25 cycles < 5% UT (>95% dip in UT) for 5 s	Mains power quality should be that of a typical commercial or hospital environment. If the user of the device requires continued operation during power mains interruptions, it is recommended that the device be powered from an uninterruptible power supply or a battery.
Magnetic fields in the Power Supply Frequencies (50/60 Hz) IEC 61000-4-8	3A/m	3A/m	Power frequency magnetic fields should be at levels characteristic of a typical location in a typical commercial or hospital environment.
Conducted RF IEC 61000-4-6	3Vrms From 150 kHz to 80 MHz	3Vrms From 150 kHz to 80 MHz	Portable and mobile RF communications equipment should be used no closer to any part of the [ME EQUIPMENT or ME SYSTEM], including cables, than the recommended separation distance calculated from the equation applicable to the frequency of the transmitter. Recommended separation distance : $d = 1,2\sqrt{P}$
Radiated RF IEC 61000-4-3	10 V/m from 80 MHz to 6 GHz	10 V/m from 80 MHz to 6 GHz	Recommended separation distance : $d = 1,2\sqrt{P}$ from 80 MHz to 800 MHz $d = 2,3\sqrt{P}$ from 800 MHz to 2,5 GHz

Note:

U_T is the AC mains voltage prior to application of the test level.

Special characteristics according to the standard NF EN ISO 17510-1:2009

Sound pressure level measured in compliance with NF EN ISO 17510-1:2009

WITHOUT HUMIDIFIER	WITH HUMIDIFIER
27.5 dBA	28.5 dBA

Sound power level measured in compliance with NF EN ISO 17510-1:2009

WITHOUT HUMIDIFIER	WITH HUMIDIFIER
35.5 dBA	36.5 dBA

Static pressure stability at 10 cm H₂O

(Long-term accuracy according to ISO 17510-1:2009, annex BB.1 and ISO 80601-2-70:2015 §201.12.1.101)

	WITHOUT HUMIDIFIER	WITH HUMIDIFIER
Pressure accuracy:	+/- 0.5 cm H ₂ O	+/- 0.5 cm H ₂ O

Dynamic pressure stability

(Short-term accuracy according to ISO 17510-1:2009, annex BB.2 and ISO 80601-2-70:2015 §201.12.1.102)

WITHOUT HUMIDIFIER	Test pressure (cm H ₂ O)														
	4			8			12			16			20		
	Respiratory freq. breaths/min			Respiratory freq. breaths/min			Respiratory freq. breaths/min			Respiratory freq. breaths/min			Respiratory freq. breaths/min		
	10	15	20	10	15	20	10	15	20	10	15	20	10	15	20
22 mm diameter tube															
Most positive pressure difference (cm H ₂ O)	0.17	0.23	0.28	0.27	0.27	0.37	0.37	0.35	0.41	0.48	0.50	0.51	0.61	0.63	0.61
Most negative pressure difference (cm H ₂ O)	0.09	0.10	0.16	0.13	0.18	0.21	0.15	0.22	0.25	0.17	0.21	0.29	0.16	0.22	0.30
Difference in dynamic pressures (cm H ₂ O)	0.09	0.04	0.05	0.06	0.08	0.09	0.11	0.11	0.15	0.18	0.19	0.20	0.16	0.26	0.20
15 mm diameter tube															
Most positive pressure difference (cm H ₂ O)	0.15	0.16	0.16	0.19	0.06	0.12	0.26	0.02	0.11	0.34	-0.02	0.12	0.45	-0.04	0.06
Most negative pressure difference (cm H ₂ O)	0.16	0.24	0.39	0.19	0.41	0.49	0.25	0.54	0.60	0.27	0.68	0.69	0.29	0.81	0.88
Difference in dynamic pressures (cm H ₂ O)	0.05	0.04	0.04	0.07	0.08	0.10	0.12	0.14	0.15	0.17	0.15	0.21	0.17	0.18	0.21

WITH HUMIDIFIER	Test Pressure (cm H ₂ O)														
	4			8			12			16			20		
	Respiratory freq. breaths/min			Respiratory freq. breaths/min			Respiratory freq. breaths/min			Respiratory freq. breaths/min			Respiratory freq. breaths/min		

	10	15	20	10	15	20	10	15	20	10	15	20	10	15	20
22 mm diameter tube															
Most positive pressure difference (cm H ₂ O)	0.20	0.25	0.32	0.29	0.32	0.39	0.34	0.40	0.50	0.42	0.49	0.60	0.52	0.61	0.70
Most negative pressure difference (cm H ₂ O)	0.05	0.09	0.15	0.07	0.13	0.18	0.13	0.15	0.22	0.15	0.19	0.25	0.16	0.18	0.27
Difference in dynamic pressures (cm H ₂ O)	0.02	0.04	0.04	0.03	0.04	0.05	0.05	0.06	0.08	0.06	0.06	0.07	0.06	0.09	0.09
15 mm diameter tube															
Most positive pressure difference (cm H ₂ O)	0.03	0.08	0.15	-0.02	0.03	0.13	-0.03	0.03	0.12	-0.01	0.04	0.17	0.01	0.08	0.19
Most negative pressure difference (cm H ₂ O)	0.27	0.33	0.40	0.38	0.43	0.51	0.48	0.53	0.61	0.56	0.62	0.70	0.65	0.70	0.79
Difference in dynamic pressures (cm H ₂ O)	0.02	0.03	0.03	0.04	0.04	0.05	0.05	0.06	0.06	0.04	0.05	0.08	0.06	0.08	0.09
15 mm diameter tube and fine filter															
Most positive pressure difference (cm H ₂ O)	0.02	0.08	0.14	-0.03	0.02	0.12	-0.04	0.02	0.12	-0.01	0.05	0.17	0.01	0.18	0.18
Most negative pressure difference (cm H ₂ O)	0.27	0.34	0.42	0.39	0.45	0.53	0.49	0.56	0.65	0.56	0.64	0.76	0.65	0.85	0.85
Difference in dynamic pressures (cm H ₂ O)	0.02	0.03	0.04	0.04	0.05	0.09	0.06	0.06	0.09	0.06	0.07	0.09	0.07	0.11	0.11

Maximum flow and pressure

(In accordance with ISO 17510-1:2009, annex CC.1 and ISO 80601-2-70:2015 §201.12.1.103)

		Test pressure (cm H ₂ O)				
		4	8	12	16	20
WITHOUT HUMIDIFIER						
Maximum flow (lpm) causing a pressure drop of 1 cm H ₂ O at the patient port	22 mm diameter tube	>124	>147	210	205	195
	15 mm diameter tube	>120	>147	195	190	180
WITH HUMIDIFIER						
Maximum flow (lpm) causing a pressure drop of 1 cm H ₂ O at the patient port	22 mm diameter tube	>126	>145	195	190	180
	15 mm diameter tube	>125	>145	180	160	150
	15 mm diameter tube and fine filter	>120	>147	150	140	130

		Test pressure (cm H ₂ O)				
		4	8	12	16	20
WITHOUT HUMIDIFIER						
Pressure measure (cm H ₂ O) at 40 l/min at the patient interface	22 mm diameter tube	3.9	7.9	12.0	16.1	20.1
	15 mm diameter tube	3.9	8.0	12.0	16.0	20.0
WITH HUMIDIFIER						
Pressure measure (cm H ₂ O) at 40 l/min at the patient interface	22 mm diameter tube	3.8	8.0	12.0	16.0	20.0
	15 mm diameter tube	3.9	7.9	12.0	15.9	20.1
	15 mm diameter tube and fine filter	3.8	7.9	11.9	16.0	20.0

Functional diagram of the internal pneumatic circuit

Device with side cover

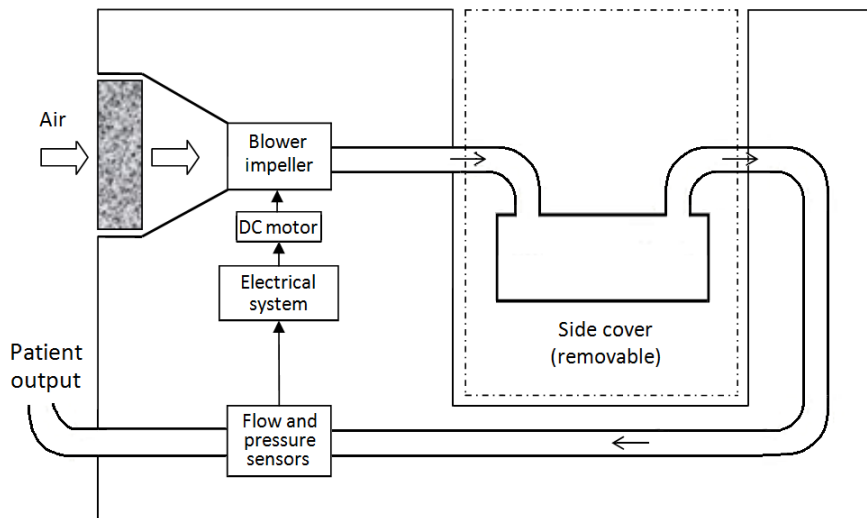

Device with humidifier

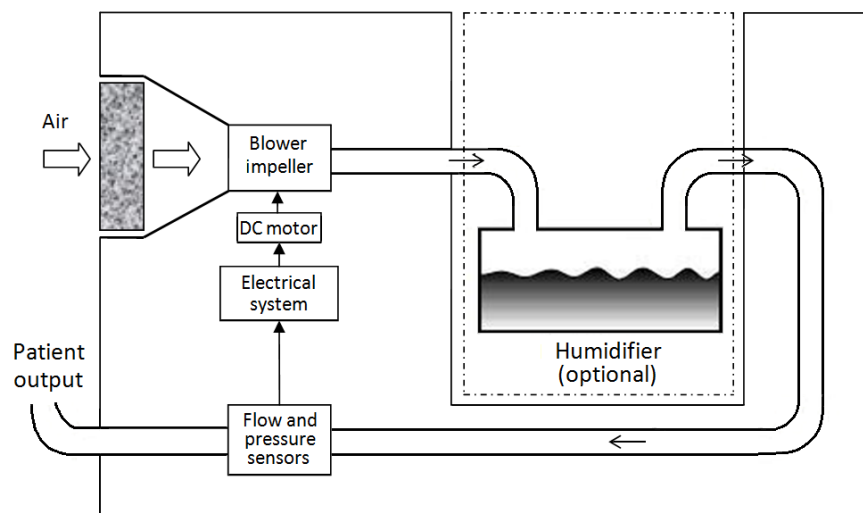

Maintenance

Views of the device



Figure 1 – Front view





Figure 2 – Rear view of a device with a humidifier



Figure 3 – Rear view of a device with a side cover



Figure 4 – View of the heater plate and accessory location

1	Start / standby button  :	To switch the device on and off.
2	Touch screen display:	To view the information and access the settings.
3	Ramp button  :	Enables or disables the ramp function when the unit is operating.
4	Button to unlock humidifier chamber or side cover:	To unlock and remove the humidifier chamber or the side cover from the machine.
5	SD card slot:	Slot for inserting the SD card.
6	USB connector:	Intended for use by your doctor or Home Care Provider.
7	Air inlet filter and grid:	Prevents dust from entering the device and the air flow path.
8	Power port:	To power the device by the power supply or by a cigarette lighter.

9	Heated tube connection:	To connect a S.Box heated tube with ATC.
10	Accessory slot:	Slot for a communication accessory (PolyLink system, S.Box modem or S.Box Wi-Fi module).
11	Heater plate (if humidifier is included):	Base of the heated humidifier used to heat the water in the humidifier chamber.
12	Humidifier humidifier chamber (if included):	Humidifier chamber in which the maximum water level is indicated.
13	Side cover (if included):	
14	Angled outlet connector:	Swivel connector for connecting the tube.

Disassembly instructions

WARNING: ELECTRICAL HAZARD

The SEFAM S.Box[®] Cpap System is electrically powered. To prevent serious injury or death, follow standard safety procedures. Ensure that power has been disconnected from the unit before servicing any component.

WARNING: ASSEMBLY PRECAUTIONS

After each repair, a leakage current testing will be required. The technical department must ensure that no external material stays inside the device and that all the repairs have been carried out in accordance with the service manual. It is the responsibility of the technical department to ensure that all these procedures have been performed in order that the device remains in conformance with the general electrical safety standard for medical equipment IEC 60601-1.

WARNING: PERFORMANCE VERIFICATION

After a component has been replaced, the unit must be calibrated and the overall system operation checked according to the "Performance Verification" section, before the unit is returned to service.

CAUTION

Circuit boards contain complementary metal-oxide semiconductor (CMOS) integrated circuits (ICs) which are static sensitive devices. To prevent IC damage, follow the standard safety procedures :

- Handle circuit boards by edges only,
- Work on a grounded conductive mat,
- Wear a grounded wrist strap,
- Store circuit board in a conductive plastic bag.

Disassembly instructions

- To remove the side cover (fig.1) or the humidifier (fig.2) from the device, Press the button to unlock the cover and at the same time, pull the cover with the integrated handle located under the cover away from the machine.

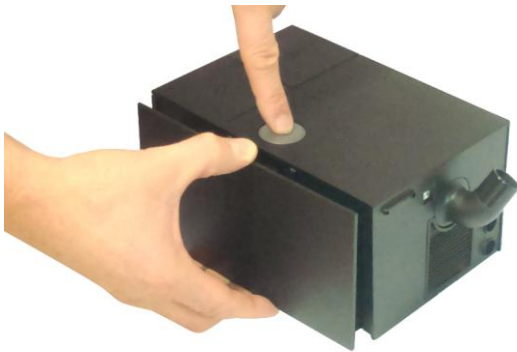

Fig.1



Fig.2

- If you have a humidifier, unlock the heater by pushing the latch to the right as indicated by  (fig.1).
- Remove the heating element by sliding it outwards (fig.1).
- If you have a communicating accessory (SEFAM S.Box® modem, S.Box® SEFAM Wi-Fi module or PolyLink system), remove it from the accessory slot of the device (fig.2).



Fig.1

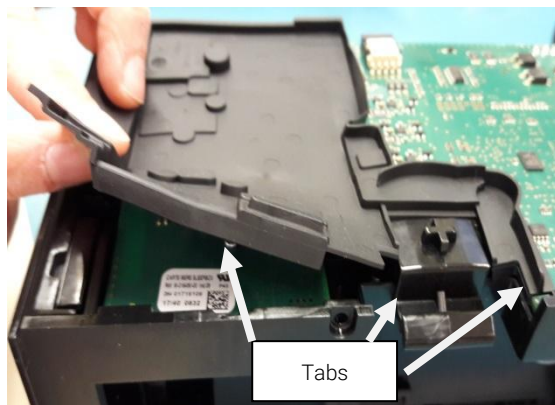

Fig.2

- Remove the 4 screws of the bottom cover with a T10 tip equipped screwdriver.



- Remove the top cover (be careful to the clip connected to the rear cover).
- Remove carefully the IP protection from the main board (take care with grooves, tabs and capacitors).



- Unlock the connector of the display ribbon on the main board (Fig.1), and remove the display ribbon from the connector (Fig.2).

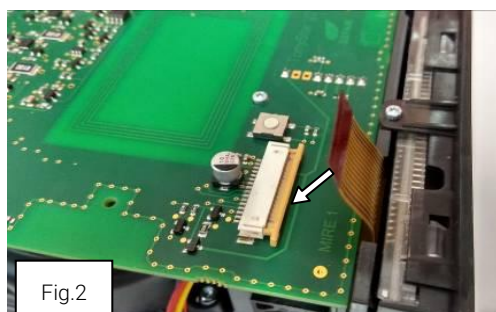
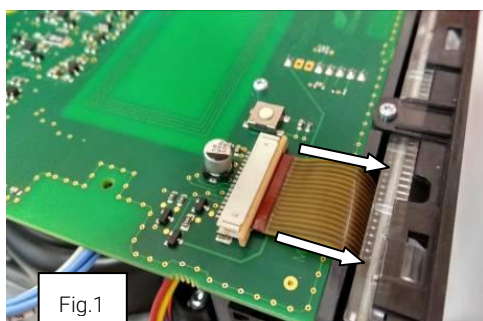

- Unscrew the screw that holds the front panel display with a T6 tip equipped screwdriver (fig.1).
- Depress the bottom of the display from its notch and slide the display upwards to remove it (fig.2).

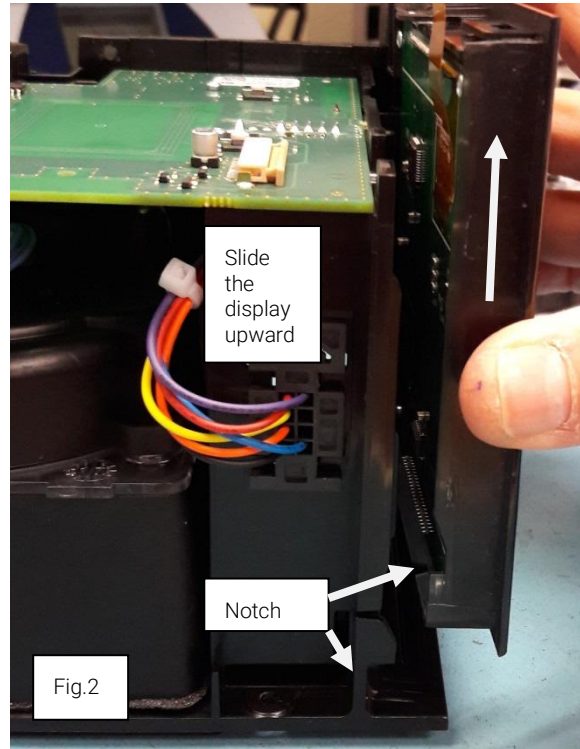
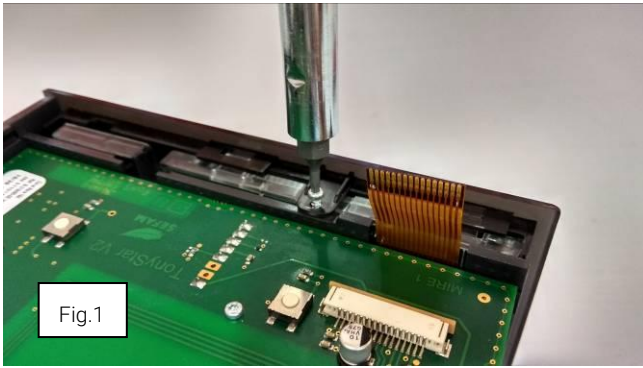

- Unscrew the screw that holds the card connectors with a T6 tip equipped screwdriver.
- Dislodge the connectors from the rear panel and remove the connector's board.

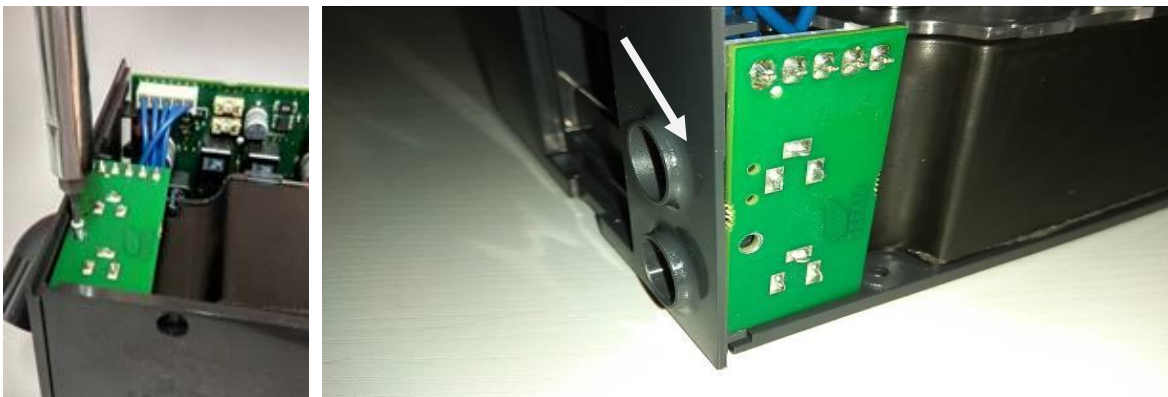

- Disconnect the turbine layer (1) and the accessory connector (2) (slide the connector upwards and remove it).

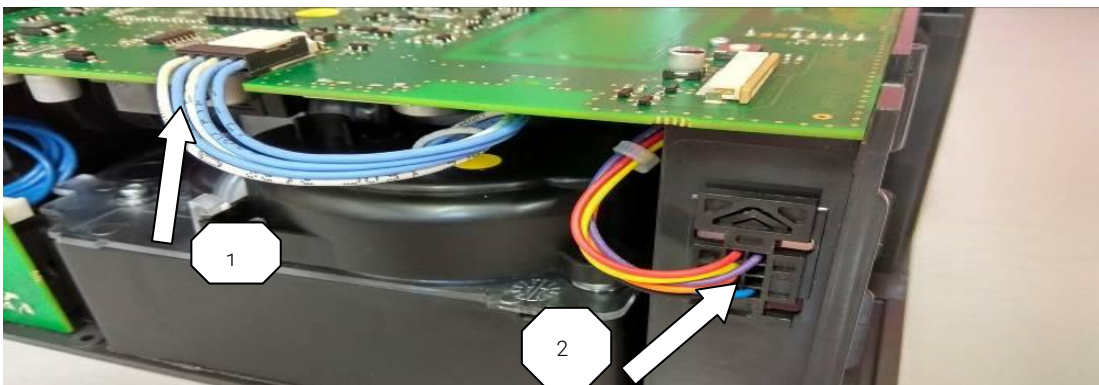

- Unscrew the 3 screws on the main board with a T6 tip equipped screwdriver.

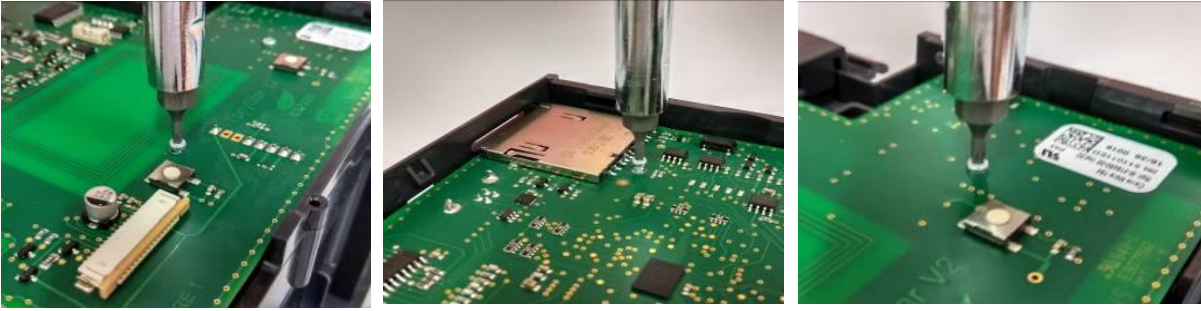

- Lift the main board slightly and disconnect the pressure/flow sensor and humidifier cables.
- Remove the main board from its location.

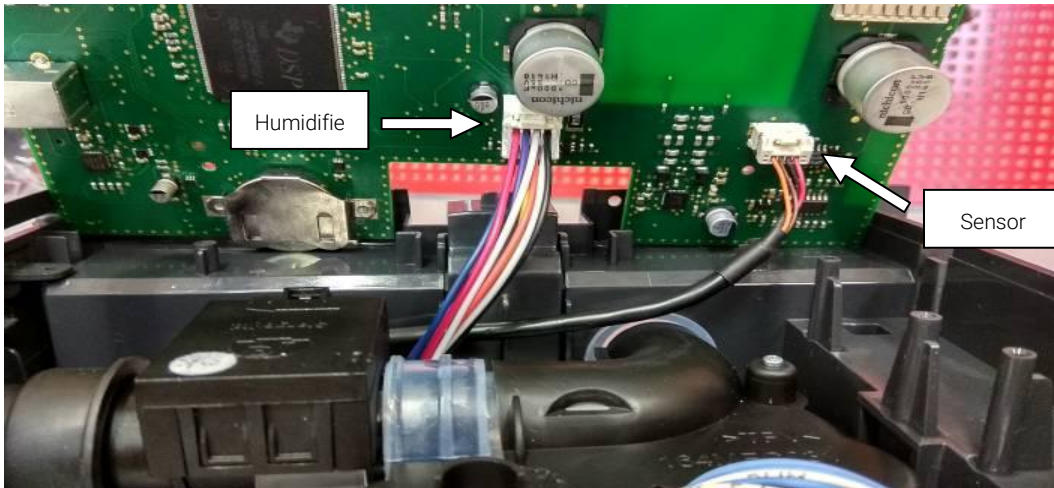

- Unscrew the screw holding the rear panel (Fig.1), remove the rear panel and the elbow seal from its location (Fig.2).

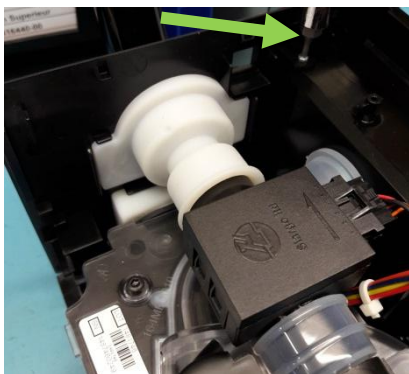

Fig.1

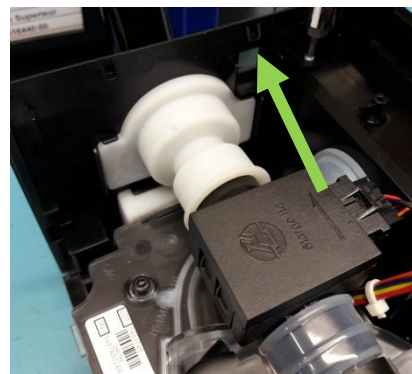

Fig.2

- Unscrew with a screwdriver equipped with a T6 tip and remove the upper frame chassis by passing the turbine cable through the rectangular opening (be careful to the holding clip) (Fig.1).
- Remove the pressure/flow sensor (Fig.2).

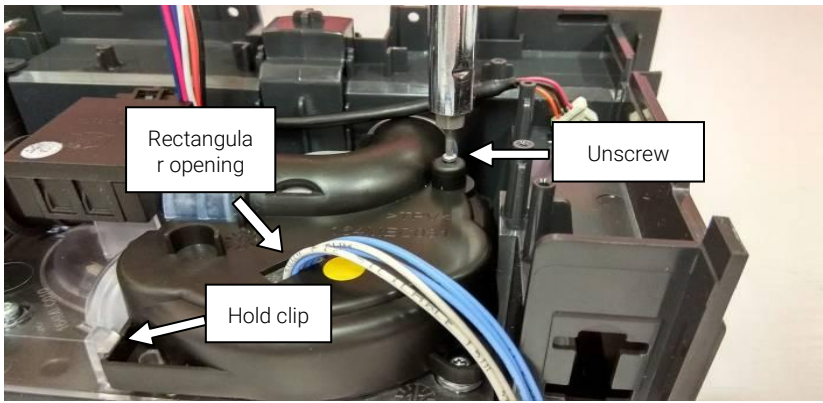
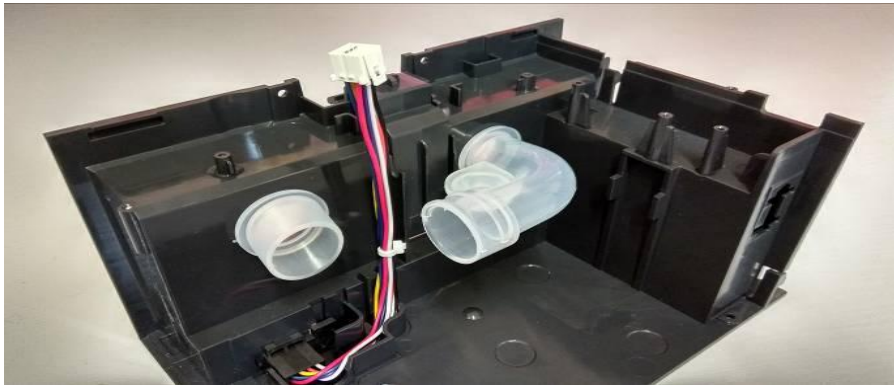

Fig.1



Fig.2

- Remove the turbine chassis from the bottom cover by gently lifting the tank outlet seal (elbow tube).



- Remove the humidifier cable from the rib (Fig.1)
- Slide the humidifier connector to the right to unlock (1) and remove the humidifier cable from the cover opening (2) (Fig.2).



Fig.1

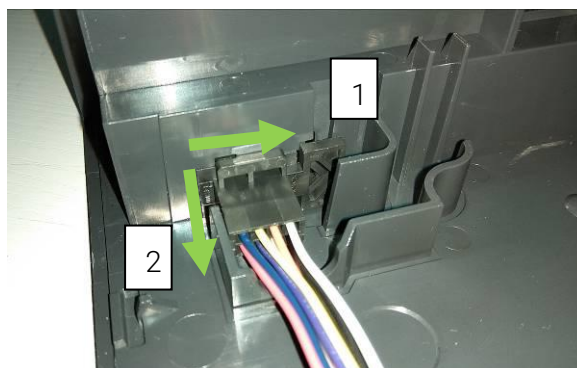
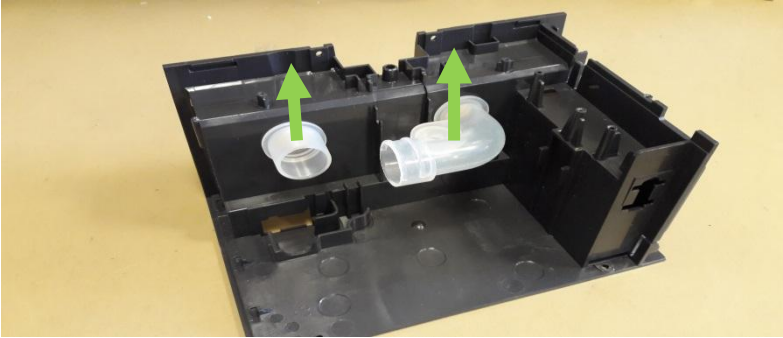

Fig.2

- Remove the tank inlet seal and the tank outlet seal from the bottom cover.



Assembly instructions

- Prepare the bottom cover.

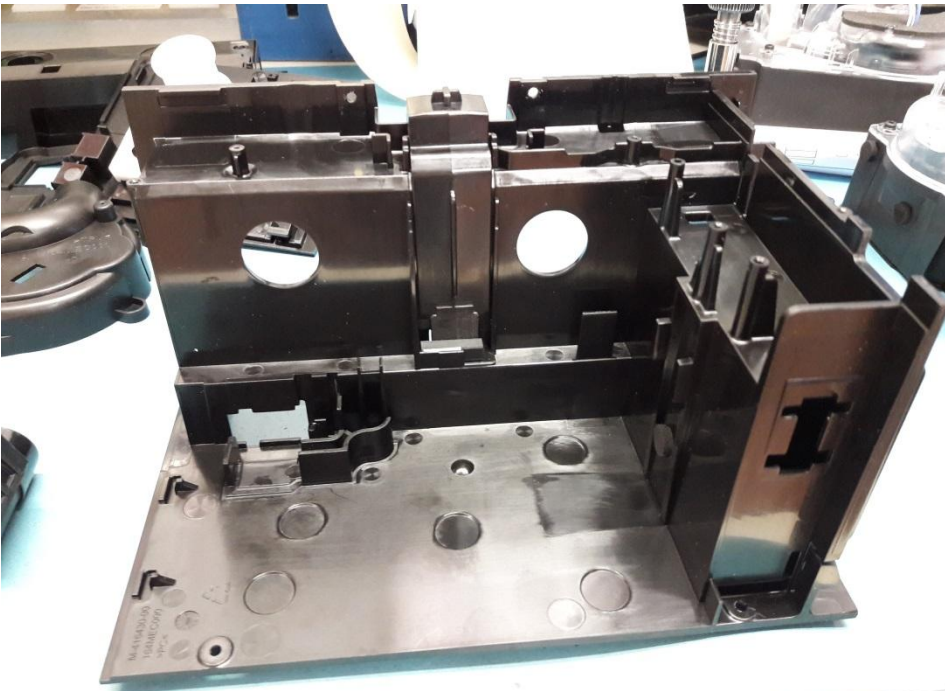

- Insert the humidifier connector in the opening of the bottom cover (1), and then slide it to the left to lock (2) (Fig.1).
- Place the humidifier cable behind the rib (Fig.2).

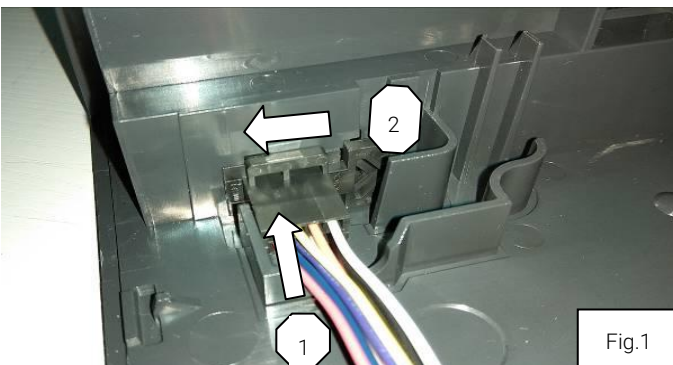

Fig.1

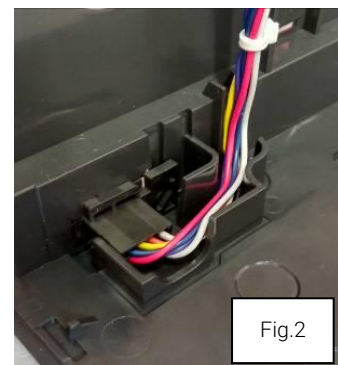
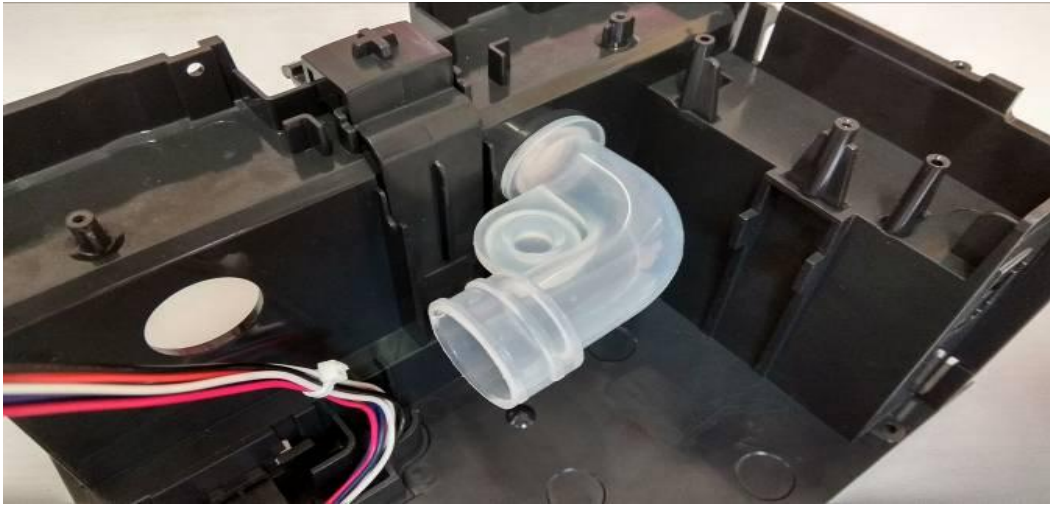
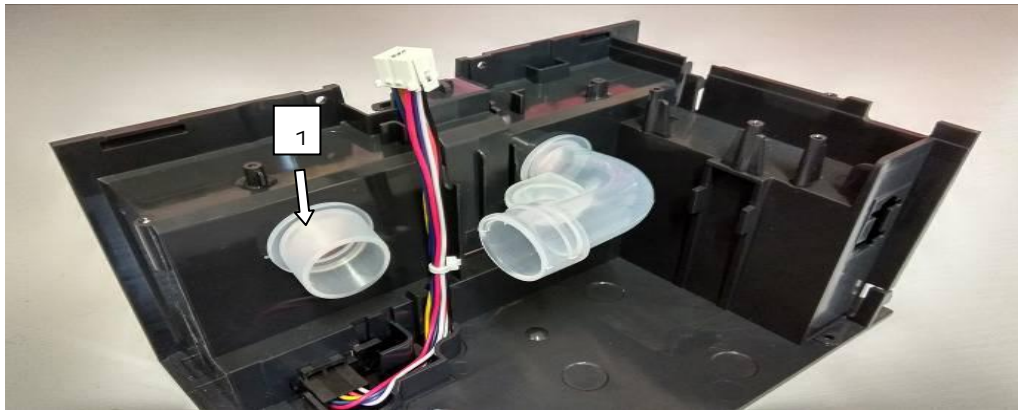

Fig.2

- Insert the tank outlet seal on the bottom cover.



- Place the tank inlet seal on the bottom cover, with the bevel facing down (1).



- Check that the two seals are correctly positioned (The holes of the bottom cover must be covered by the seals).

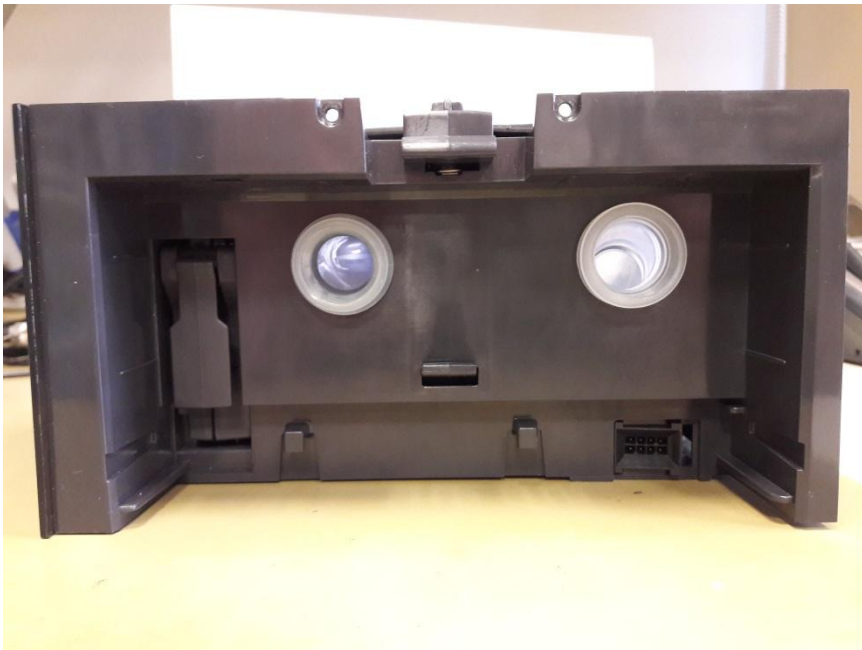

- Place the turbine chassis on the bottom cover by sliding it into the tank inlet seal (1) while lifting the tank outlet seal (2).
- Check that the Humidifier cable is in the notch provided on the turbine chassis.

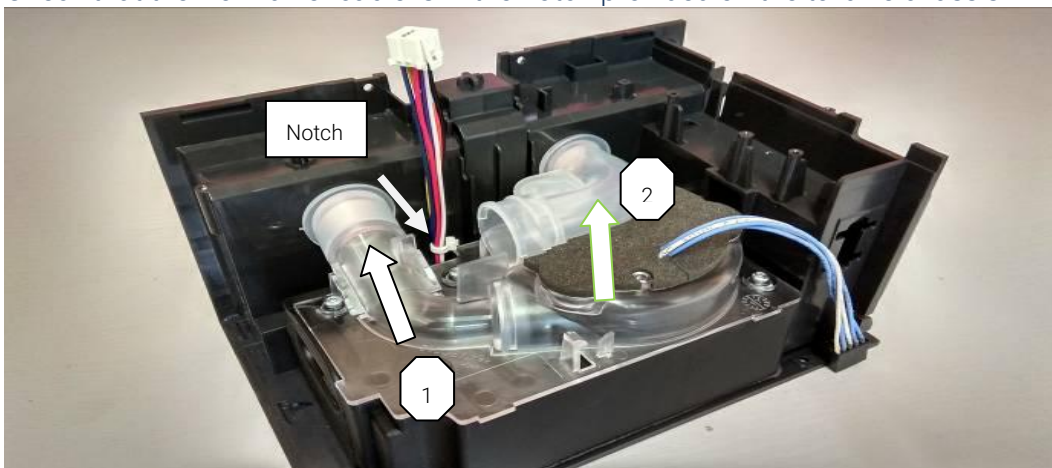

- Assemble the cable on the pressure/flow sensor.



- Place the pressure / flow sensor against the air outlet seal (mark the direction of the sensor with the arrow on the sensor ()).

- Place the air outlet seal locating on the turbine chassis location.

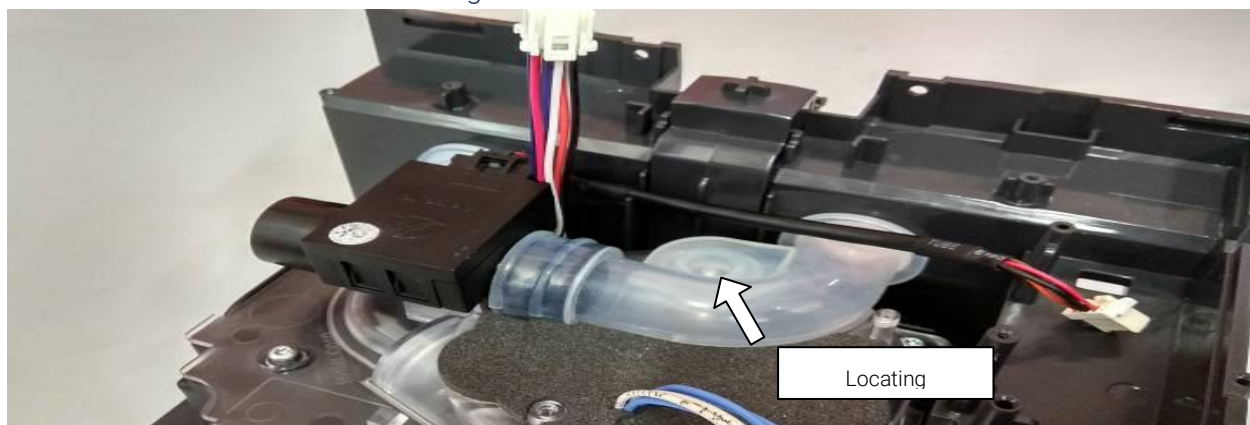

- Place the top turbine chassis shell by passing the turbine cable through the shell cutout.
- Screw with a T6 tip equipped screwdriver, until it locks (do not force).
- Check that the holding clip is in position.

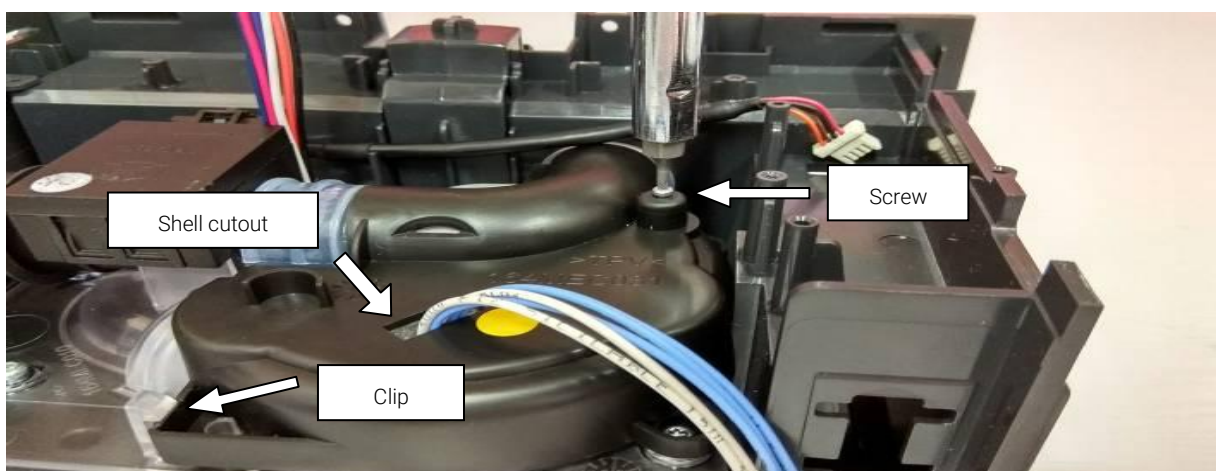

- Place the elbow seal and the air inlet seal on the rear cover

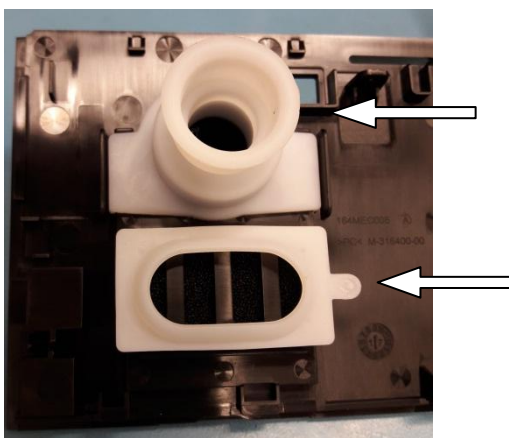

- Engage the elbow seal on the pressure/flow sensor, while positioning the 3 ribs at the bottom of the rear cover on the bottom cover.
- Screw with a T6 tip equipped screwdriver, until it locks.

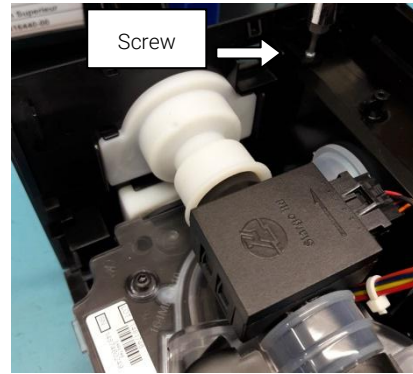
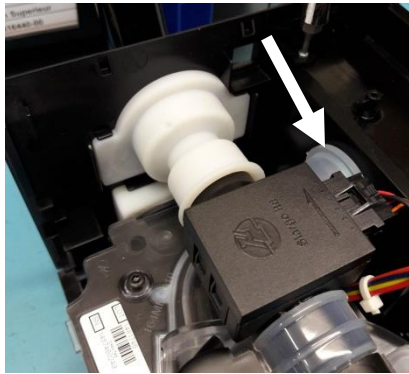

- Connect the pressure / flow sensor and humidifier cables to the main board (sensor cable passing in front of the humidifier cable).
- Place the main board on the bottom cover. Align the back of the main board with the rear cover, while positioning the pressure/flow sensor cable between the 2 capacitors.

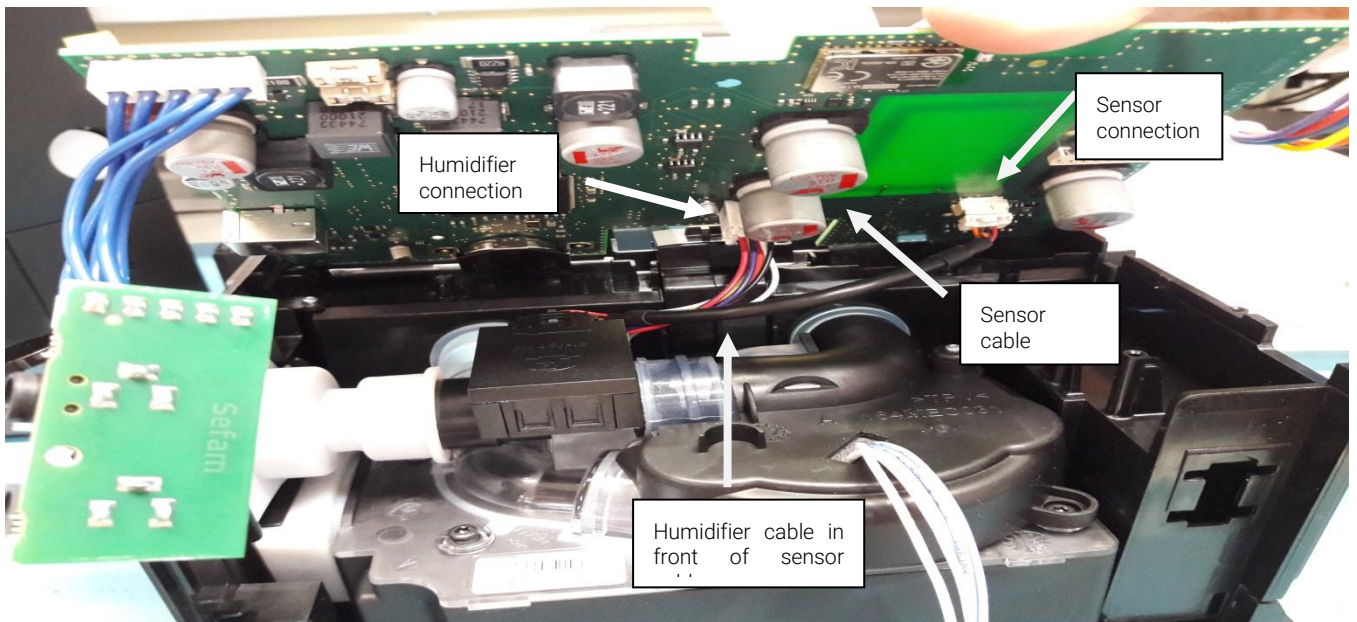

- Place the connector board in its back cover slot (insert the connectors in their slots).



- Place the accessory connector in the opening of the bottom cover (1) and slide it up to lock (2).
- Connect the turbine cable to the connector on the main board (3).

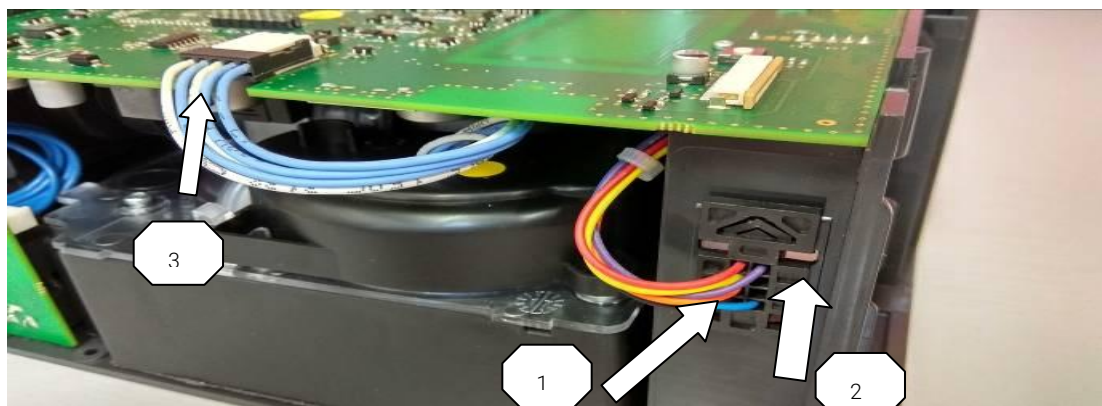

- Check that the turbine cable and accessory cable pass behind their guides.



- Screw the 3 screws with a T6 tip equipped screwdriver until they are locked.



- Screw the connector board with a T6 tip equipped screwdriver until it locks.



- Place and slide down the front panel display on the bottom cover and engage the notch in its position.

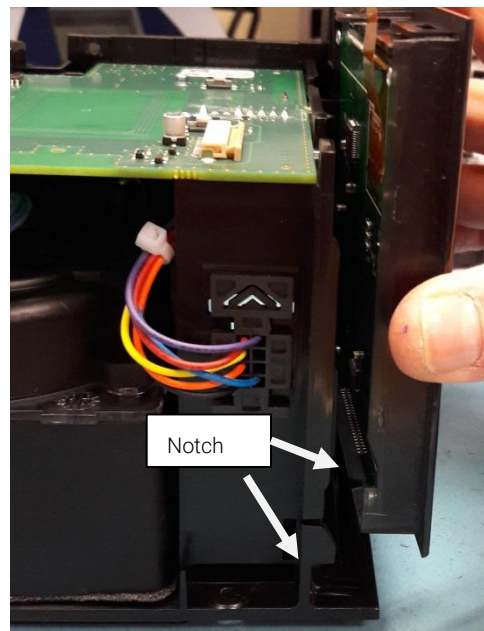

- Screw the front panel display with a T6 tip equipped screwdriver, until it locks.

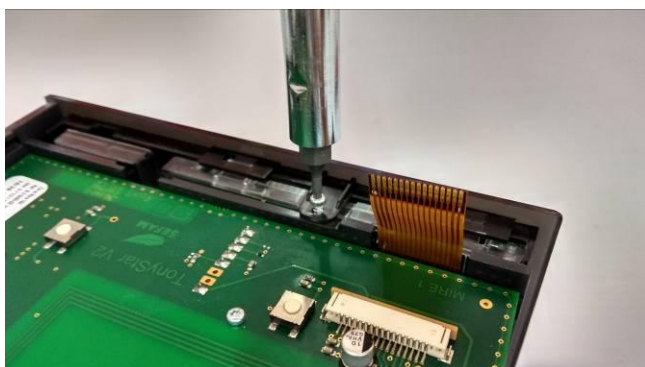

- Connect the display ribbon into the main board connector (Fig.1).
- Lock the connector (Fig.2).

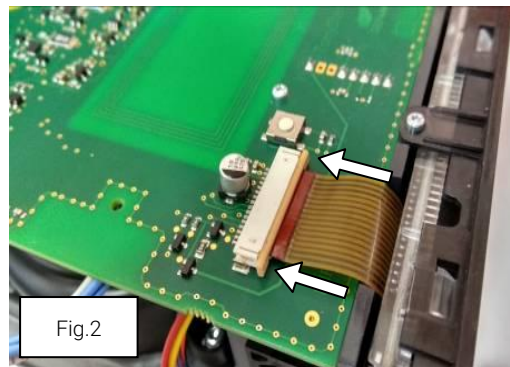
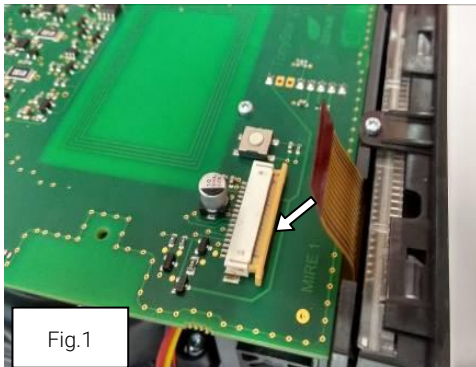

- Place the IP protection on the main board. Place the IP protection carefully on the capacitor (Fig.1).
- Slide the IP protection tabs between the edge of the main board and the bottom cover. (Fig.2).

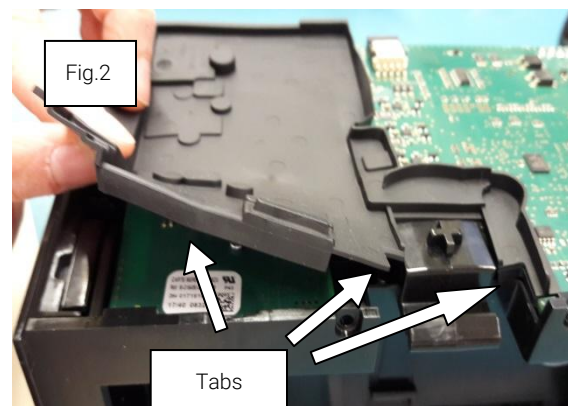
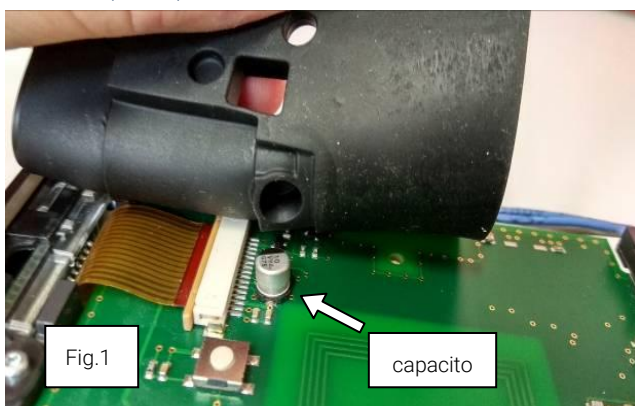

- Place the top cover (check that it is inserted into the rear panel rib).
- Close the top cover by tightening the 4 screws with T10 tip equipped screwdriver, until it locks.



- Insert the communicating accessory (SEFAM S.Box® modem, SEFAM S.Box® Wi-Fi module or PolyLink system) for equipped devices (Fig.1).
- Insert the side cover (you have to hear a "click" of locking mechanism).
- For units equipped with a humidifier, insert the heating element by sliding it inward and lock it by pushing the latch to the left as indicated by  (Fig.2).



- Insert the humidifier chamber by sliding it on the heating plate, for the configuration with humidifier chamber (you have to hear a "click" of locking mechanism).



Pressure Verification

Frequency and required equipment

Pressure control can be done once a year (recommended but not mandatory).

Required equipment :

- A calibrated pressure meter 0-30 cm H₂O
- A Ø 22 or 15mm patient tube
- A test kit (consist of a coupling and a stopper with a 4mm diameter leak).

Pressure control

- Connect your device to a power source, select the CPAP mode (see § "how to set the device"), set the pressure to 12cmH₂O.
- Select Ø 22mm or Ø 15mm pneumatic calibration (following the tube used) (see § 7- "circuit select").
- Connect the patient tube to the S.Box air outlet and connect the free end piece of the patient tube (equipped with a Ø 4mm leak) to the pressure controller.



- Start the treatment and wait for 1 minute.
- Check the pressure value measured by the controller. This value must be 12cmH₂O +/- 0.5.
- If the pressure is not correct, it must be adjusted, in this case an automatic calibration of the pressure sensor is necessary (see § "How to set the device, 13- Pressure and flow offset").

Spare parts

Reference	Description
M-416410-00	S.Box power supply
M-316430-03	Side cover S.Box (Ext)
M-316420-01	S.Box heated element
M-216430-06	S.Box heated humidifier
M-216430-15	S.Box Humidifier chamber
M-216430-16	S.Box Humidifier chamber base part
M-316470-01	Display S.Box (Ext)
M-316490-01	Main board S.Box (Ext)
M-316450-01	Internal frame ASSY S.Box (Ext)
M-316490-03	Flow sensor S.Box (Ext)
M-315940-01	Inlet air filters (50 pcs)
M-316400-02	Air inlet filter grid S.Box (Ext)
M-316400-01	Rear cover S.Box (Ext)
M-316430-01	Bottom cover S.Box (Ext)
M-316440-01	Top cover S.Box (Ext)
M-216430-09	S.Box USB cable
M-216430-05	S.Box SD card



Manufacturer:

SEFAM
144 AV CHARLES DE GAULLE
92200 NEUILLY SUR SEINE
FRANCE

Manufacturing plant:

SEFAM
10 ALLÉE PELLETIER DOISY
54600 VILLERS-LES-NANCY
FRANCE

REF : M-164MAT00-10-Version 1
2018-01